



# User's Manual

LED UV Curing System Aicure SPOT Type

**UJ30/35 Series**

---





# LED product safety precautions

The purpose of the following caution indications is to ensure the safe and correct use of this product, in order to protect users from injury and prevent property damage.

The caution indications to prevent possible human injury and property damage caused by incorrect use are classified by “**DANGER**” and “**WARNING**” depending on their degree and severity.

**All caution indications are critical for ensuring safety and must be strictly observed.**

 **DANGER** Failure to observe the instructions can result in death or serious injury.

 **WARNING** Failure to observe the instructions can result in injury or property damage.





Symbol examples





This symbol denotes a **Prohibited** action.  
The left-hand example denotes “Do not disassemble”.



This symbol denotes a **Mandatory** action or an **Instruction**.  
The left-hand example denotes “Mandatory”.

 <b>DANGER</b>	
 Prohibited	<ul style="list-style-type: none"> <li>● Do not use this product in a space in which combustible gases may be present. (To avoid the risk of explosion.)</li> <li>● Do not dispose of this product in a fire. (To avoid the risk of batteries or electronic parts exploding.)</li> </ul>
 Mandatory	<ul style="list-style-type: none"> <li>● While the LED is lit do not look at direct or reflected radiation, and do not allow anyone to approach. (To avoid the risk of injury or inflammation to eyes and skin.)</li> <li>● Always wear UV protective goggles and protective gear when using this product. (To avoid the risk of risk of injury or inflammation to eyes and skin.)</li> </ul>
 Do not disassemble	<ul style="list-style-type: none"> <li>● Never try to disassemble or modify this product. (To avoid the risk of generating abnormal heat or smoke. Also, disassembling the LED head may expose eyes and skin to LED-UV radiation, resulting in injury or inflammation.)</li> </ul>

 <b>WARNING</b>	
 Mandatory	<ul style="list-style-type: none"> <li>● To prevent the generation of abnormal heat or smoke, always use this product with an adequate margin of safety with respect to its guaranteed characteristics and performance values.</li> <li>● Do not touch the terminals while they are electrically powered. (To avoid the risk of electric shock.)</li> <li>● Make sure to connect the power cable and connectors securely. (To avoid the risk of generating abnormal heat or smoke.)</li> <li>● Make sure to plug in the AC adapter securely. (To avoid the risk of generating abnormal heat or smoke.)</li> </ul>
 Prohibited	<ul style="list-style-type: none"> <li>● Never insert any foreign substances such as liquid, flammable materials, or metals inside the product. (To avoid the risk of generating abnormal heat or smoke.)</li> <li>● Never perform any setup work (e.g., connection, disconnection) with the power cable plugged in. (To avoid the risk of electric shock.)</li> <li>● Never place anything on top of the product or obstruct the ventilation openings in any way. (To avoid the risk of burning due to overheating.)</li> </ul>

# LED product safety precautions

---

## LED Product Handling Overseas

According to the exemption from "Safety of Laser Products (IEC60825-1)", "Photobiological safety of lamps and lamp systems (IEC62471)" is applied to LED products.

This product corresponds to Risk Group 3 in the IEC62471 (ANUJ6187/6189 is Risk Group 2.) standard. In consideration of users' safety, however, conduct safety management equivalent to Class 3B laser for this product.

\* This product is designed to comply even with IEC62471.

## LED Product Classification

The light source of the LED head connected to this product is classified as 3B under the JIS C6802 "Safety of laser products."

Max output: 990mW Class 3B LED Product	Wavelength: 365±5 nm JIS C6802: 2005
Max output: 1180mW Class 3B LED Product	Wavelength: 385±5 nm JIS C6802: 2005
Max output: 1530mW Risk Group 2 LED Product	Wavelength: 405±5 nm JIS C7550:2011

 **DANGER**

Controlling or calibrating this product by other than the procedures stipulated here could cause exposure to dangerous LED radiation.

## Safety Precautions for Users

JIS C6802 stipulates user guidelines pertaining to safety precautions to be taken by users and management standards.

In the case of this product, please implement safety precautions for a class 3B LED product. See JIS C6802, "Safety of laser products" for details. In the abroad, see the standard according each country.

# LED product safety precautions

## Laser products Preventive safety measures for users (summary)

[from JIS “Safety of laser products”]

Required item/ Article	Classification						
	Class 1	Class 1M	Class 2	Class 2M	Class 3R	Class 3B	Class 4
Laser safety manager 10.1	Not necessary, but it is recommended that one be appointed in the case of applications where laser beams can be directly observed				Not necessary in the case of visible light beams. Necessary in the case of invisible light beams.	Necessary	
Remote interlock 10.2	Not necessary					Connected to a room or door circuit	
Key control 10.3	Not necessary					Remove the key when not in use	
Beam attenuator 10.4	Not necessary					Avoid careless irradiation during use	
Emission indication device	Not necessary				Indicates that laser is operating at an invisible wavelength.	Indicates that laser is operating	
Warning indication 10.5	Not necessary					Follow warning indication preventive measures	
Beam path 10.6	Not necessary	Same as Class 3B for Class 1M	Not necessary	Same as Class 3B for Class 2M	Terminate beam at end of effective length		
Specular reflection 10.7	No necessary items	Same as Class 3B for Class 1M	No necessary items	Same as Class 3R for Class 2M	Avoid unintended reflection		
Eye protection 10.8	No necessary items					Necessary if it is not possible to execute technical and management procedures, and if MPE (max. permissible exposure) is exceeded	
Protective clothing 10.9	No necessary items					Sometimes necessary	Specific instructions are necessary
Training 10.10	No necessary items	Same as Class 3R for Class 1M	No necessary items	Same as Class 3B for Class 2M	Necessary for all operators and maintenance personnel		

# LED product safety precautions

## Safety features

This product is equipped with the following safety features, based on JIS C6802 “Safety of laser products.”

### ■ Remote interlock

UV irradiation can be stopped by opening the INPUT terminal “INTERLOCK (11)” on the rear of the controller. It is shorted with a shorting bar as a factory default.

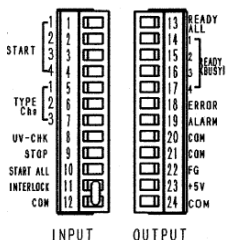

### ■ Control by a key switch

The controller unit of this product is started via a key switch. Ensure that the key is removed while this product is not in use.

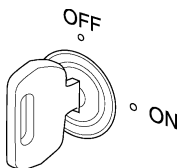

### ■ LED radiation emission warning

Turning ON the key switch enables the irradiation of LED UV light, which turns on the irradiation warning indicator on the front panel of the controller. If the LED connection cable is longer than 2 m, or if the controller unit is installed in an invisible part of the equipment, another warning indicator needs to be provided in a visible location around the LED head.

(OUTPUT terminals “+5V” (23) and “COM” (24) on the rear of the controller output signals when the key switch is turned ON.)

Stays on during irradiation

The emitting channels are indicated by a red light, either still or flashing.

### ■ Emergency reset

If an error occurs, eliminate the cause and then hold down “SET” for more than one second to clear the error.

# LED product safety precautions

## Labels

The LED irradiation warning labels (shown below specified by JIS C6802) shown below are attached to the LED heads before this product is shipped from the factory. Warning labels in Chinese that comply with GB standards and those in English that comply with IEC/EN standards are also included.

### ■ Warning labels in Japanese (JIS)



### ■ Description

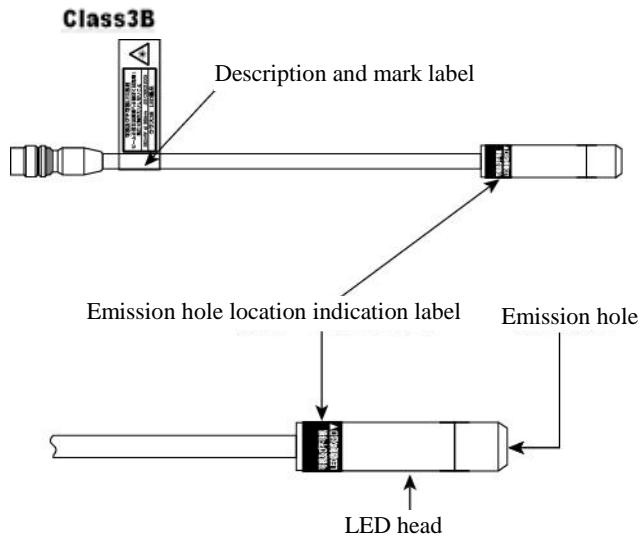

### ■ Warning labels in Chinese (GB standards)

If this product is used in China, apply the labels shown below over the Japanese labels.



### ■ Warning labels in English (IEC/EN standards)

If this product is used outside Japan or China, attach the labels shown below over the Japanese labels.



# Precautions for use

---

## ■ General precautions



- Never connect any LED head, connection cable, AC adapter, or UV sensor to the main unit, other than those designated by Panasonic. Otherwise, any failure, loss, or damage that may occur will not be covered under warranty.
- Never try to disassemble or modify the product, or to alter its internal settings. Any failure or damage that occurs after disassembling or modifying the product will not be covered under warranty.

## ■ Installation environment

- Ambient temperature      Controller: 0 to +35°C (with no condensation)  
   LED head: +5 to +35°C (with no condensation)
- Ambient humidity:      30 to 85% RH (at 25°C, with no condensation)
- A location free of dirt, smoke or soot, conductive dust, and corrosive or flammable gases, where there is no risk of exposure to water, oil, or chemicals
- A location not subject to sudden temperature changes, or to vibration and physical shock
- A location not exposed to direct sunlight

## ■ Power supply

- Supply electric power of 100 to 240 V AC (frequency: 50/60 Hz, current 1.2A).
- Supply electric power of 5 to 28 V DC to the input/output terminals.
- Outside Japan, please prepare and use AC power cable that complies with the standard of the country of use. (AC inlet standard for AC adapter: IEC60320-C8)
- Do not connect this product to a power supply that is shared with equipment that includes an electric motor or other high-power usages. Use a separate power supply and make sure to provide a protection circuit (e.g., a fuse).
- Take care to prevent excessive static electricity accumulation.
- If using multiple units of this product, do not tie their AC adapters together in a bundle. Otherwise, the AC adapters may overheat, resulting in failure.
- If the product is to remain unused for any length of time, disconnect the power plug from the power socket.
- The symbols below indicate DC, AC, and double insulation on the rating plate of the controller and AC adapter. (Symbol defined by IEC60417)

Controller	DC (direct current)	
AC adapter	AC (alternating current)	
Class II Equipment	(double insulation)	

### ■ Wiring

- If any device connected to this product is connected to a DC induction load (motor or relay), connect a noise absorption device (e.g., noise suppressor) on the side of the load.
- When connecting an external power source to the input/output terminals, make sure that the polarity is correct.
- Make sure to perform wiring so that no physical or electrical load is added to the connection cable. Also, avoid bending too close (less than 80 mm) to the base (connector part) and make sure that the radius of bends is at least 33 mm.
- Make sure to hold the connector (plug) part while connecting or disconnecting the power cable.
- If the connection cable is longer than 2 m, or if the product is installed inside a larger item of equipment, set up a display near the LED head so that the “LED radiation warning” can be readily seen. If you use OUTPUT terminals “+5V” (23) and “COM” (24) at the rear of the controller, these will output a signal when the power is switched ON.

### ■ Setup

- Check that the rubber feet of the product are always horizontally level. Never incline the product, or position it on its side, or upside down. Otherwise, overheating may occur, resulting in failure and damage.
- Never place anything on top or below the product, or obstruct the ventilation openings in any way. Otherwise overheating and burning may occur. Provide for sufficient ventilation space around the product: Top: 50 mm; Sides: 20 mm; Rear: 80 mm.
- When LED-UV light is in danger of being exposed to reflected UV light, cover the light with an enclosure that has appropriate reflectance that cuts off the reflected light and thermal properties.
- Install a protector so that people stay back from LED-UV light while this product is in operation.
- When irradiating onto an object with high reflectance such as mirrors, install it so that the reflected UV light won't go directly into the LED head.

### ■ Precautions when powering ON

- Check that all connections are correct before powering ON.

### ■ Other precautions

- When disposing of this product, it should be treated as industrial waste.

## Precautions for use

---

### Warranty Period

- The Warranty Period for this product (excluding LED head, UV sensor and AC adapter) is 3 years from either the date of purchase or the date on which the product is delivered to the location specified by the Buyer. However, the Warranty Period shall be valid only until 42 months from the date of manufacture which includes a maximum of 6-month distribution period. The warranty period for the LED head extends until one year from the time of delivery, or until 5,000 hours of cumulative irradiation, whichever is sooner.

### Extent of Warranty

- In the event of any failure or defect in the product or non-conformity of specifications due to the reasons solely attributable to the Seller, Seller shall remedy such malfunctioning or defective product at its own cost in one of the following ways to be selected by SELLER: (i) repair such product, (ii) replace such product, (iii) supply of replacement parts. However, this Warranty shall not cover the damages or defects that arise due to the reasons any of the followings.
  1. Specifications, standards or handling procedures specified by the Buyer.
  2. Modifications to the structure, performance or specifications performed by a party other than the Seller after the date of purchase or the date on which the product is delivered.
  3. Phenomena that could not have been foreseen with the technology that was put into practical use at the time of purchase.
  4. Exceeding the ranges, conditions, circumstances or environment described in the Manuals or Specification sheet.
  5. Damages that could be avoided if Seller's product have the functions and structures generally accepted in the industry, when incorporating the product in to Buyer's product.
  6. Natural disasters or an Act of God.
  7. Consumable goods such as batteries and relays, or optional accessories such as cables.
- **SELLER SPECIFICALLY DISCLAIMS ALL IMPLIED WARRANTIES OF MERCHANTABILITY AND/OR FITNESS FOR A PARTICULAR USE OR PURPOSE, AS WELL AS LIABILITY FOR INCIDENTAL, SPECIAL, INDIRECT, CONSEQUENTIAL OR OTHER DAMAGES RELATING TO THE PRODUCT.**

#### Product EOL ("end of life")

- Please understand that production of this product may be discontinued at any time for a variety of possible circumstances. Note that repair services are not provided after a product is discontinued.

1	Features of the ANUJ 3000/3500 .....	12	7	External control.....	36
2	Product components.....	14	7.1	External input/output control.....	36
3	Parts names and functions.....	15	7.2	Serial communication control .....	38
4	Installation .....	17		RS-232C terminal specifications .....	38
4.1	Installation conditions .....	17		Communication specifications.....	38
4.2	General guidelines for irradiation distance and UV intensity.....	19		Commands and responses .....	38
5	Getting started.....	21		Command/response format .....	39
5.1	Hooking up the connection cable .....	21		Block check code BCC (H) (L).....	39
5.2	Connecting the LED .....	21		Control commands.....	40
5.3	Connecting the external control signals.....	23		Support commands .....	40
5.4	Connecting the AC adapter .....	24		Error codes .....	40
5.5	Power on operation .....	24		Data areas .....	41
6	Operation modes .....	25	7.3	Communications address map.....	42
6.1	Operation mode (default mode when power is turned on).....	25		Address for reading .....	42
	1) Setting irradiation conditions .....	26		Address for writing.....	46
	2) Timer irradiation.....	26		WRITE procedure.....	50
	3) Continuous irradiation .....	27	7.4	Setup tool application for UJ35.....	53
	4) Irradiation using an external start signal .....	27		Operation from a PC.....	53
	5) Display of head management information .....	28	8	Warning indications .....	59
	6) Panel lock function .....	28		Temperature warning .....	59
6.2	UV measurement and Calibration mode.....	29		Time warning.....	59
	1) Measuring UV intensity.....	29		Error codes .....	60
	2) Calibration .....	30	9	Safety measures .....	61
6.3	Default settings mode.....	31	9.1	Safety circuit.....	61
6.4	Timing chart.....	32	10	Specifications.....	62
	1) Batch irradiation .....	32	10.1	Outline of specifications.....	62
	2) Individual irradiation .....	34		Controller specifications.....	62
				Head specifications .....	63
				UV sensor specifications .....	65
			11	Dimensions.....	66
			12	Option and spare parts list.....	67
			12.1	Options and spare parts .....	67
			12.2	How to replace the lens unit .....	69
			12.3	Fitting the mounting bracket .....	69
			13	Troubleshooting .....	70
				Manual revision history .....	71

# 1 Features of the ANUJ 3000/3500

The ANUJ 3000/3500 is an UV curing device that quickly hardens UV resins (inks, adhesives, and coatings) via irradiation with UV light from an LED light source. The focused application of UV radiation to UV resins coated on minute surfaces (2 to 3 mm dia.) such as the lenses of CD, MD, and DVD players, and the LCD panels of notebook PCs, enables precise adhesion.

■ High-power irradiation: 17,200 mW/cm<sup>2</sup> (wavelength of 365 nm), 19,500 mW/cm<sup>2</sup> (wavelength of 385 nm), 20,900mW/cm<sup>2</sup> (wavelength of 405nm) ( ANUJ6423 lens equip the ANJU6186/6188/6189 )

Higher radiation intensity and a wider range of applications. Shorter production cycles.

■ Long-lasting cost effective LED type. (LED life: Total irradiation time before UV intensity falls to 70% of initial value)

The LED life is significantly longer than the lamp life, and running costs can be reduced. Also, unlike a lamp, it does not generate ozone, eliminating the need for an exhaust duct, which greatly contributes to the reduction of maintenance and installation man-hours.

■ UV curing without temperature increases

Uses a single 365-nm, 385-nm, 405-nm LED UV light source that does not emit any infrared radiation, eliminating the risk of heat damaging the workpiece.

■ UV intensity stabilization

UV intensity is kept constant, even if the ambient or LED temperature changes.

■ Easy-to-install LED head

At 12 mm dia. by 50 mm len., the LED is easy to mount on a jig. Mounting the LED head in place reduces overheating and increases UV intensity.

■ No cooling fan, enabling cleanroom use

There is no need to deal with exhaust.

■ Programmable UV irradiation with four independently controlled heads \*

Each LED head can be controlled independently. The heads can also be controlled all together or in combination. Up to eight different operation programs can be stored for each channel, including one program for the constant intensity irradiation and seven programs composed of up to 10 steps each.

\* The function of programmed irradiation is provided with UJ35 only.

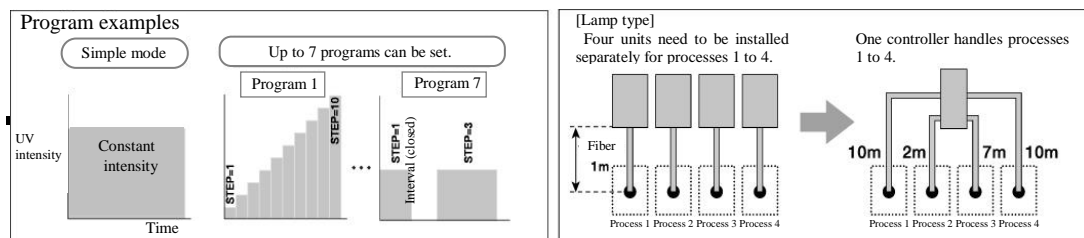

## Features of the ANUJ 3000/3500

---

### ■ The Universal design for easy operation

Easy operation has been achieved by the product's universal design, including the large-sized color LED display with a high level of visibility and the operation switches located at optimal locations.

After connecting the head, UV irradiation can be started simply by selecting a channel (CH), setting the UV power (%) and irradiation time (TIME), and then pressing [EMISSION].



### ■ Multiple safety features

Circuit breaks and short circuits of the LED head are automatically detected. If the LED overheats due to high ambient temperature or other reason, it turns itself off. UV irradiation can be brought to an emergency by opening INPUT terminal “INTERLOCK” (11) on the rear of the controller. Irradiation can also be stopped by short-circuiting “STOP” (9) and “COM” (12).

### ■ Detachable terminal blocks for external connection

The detachable terminal blocks facilitate connections with external equipment.

### ■ AC-free power supply

100 to 240 V  $\pm$  10% dedicated AC adapter.

(The AC adapter power cable of the attached model is Japan PSE standards compatible cable (100V AC))

## 2 Product components

### Controller

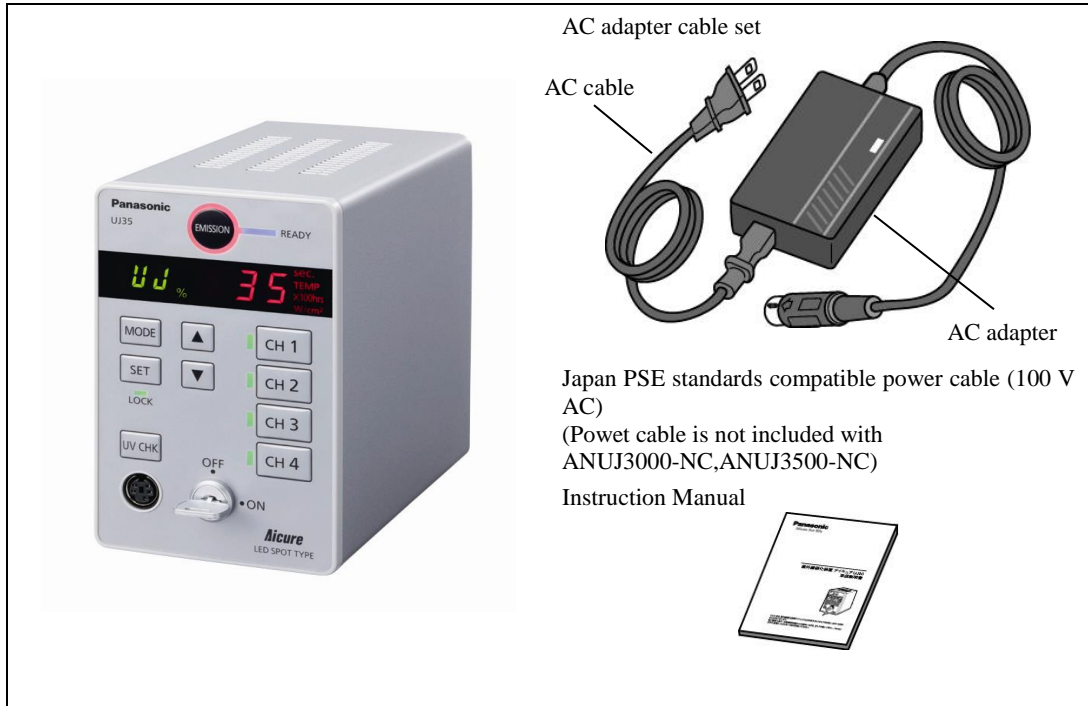

### Optional parts (sold separately)

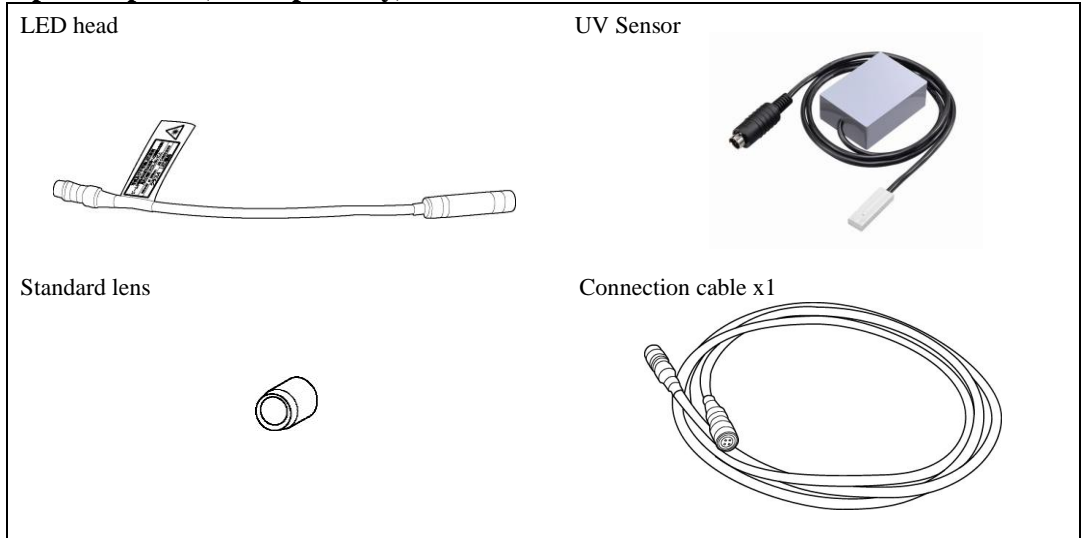

### 3 Part names and functions

Front of the controller



UV sensor (option)



Rear of the controller

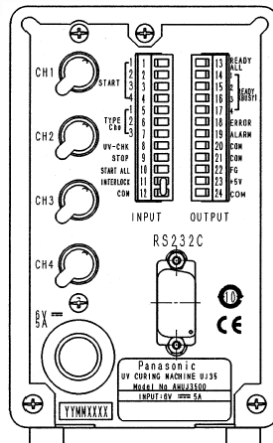

AC adapter

(Power cable is not included with ANUJ3000-NC, ANUJ3500-NC)

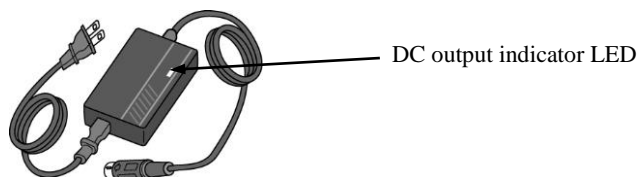

# Part names and functions

## ● Front

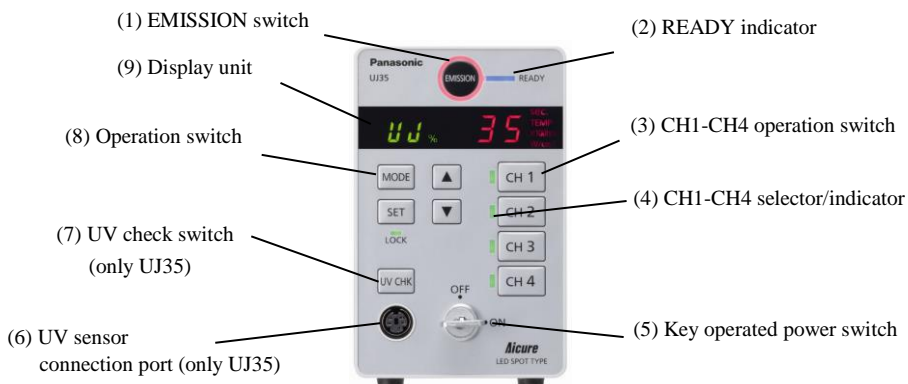

## ● Rear

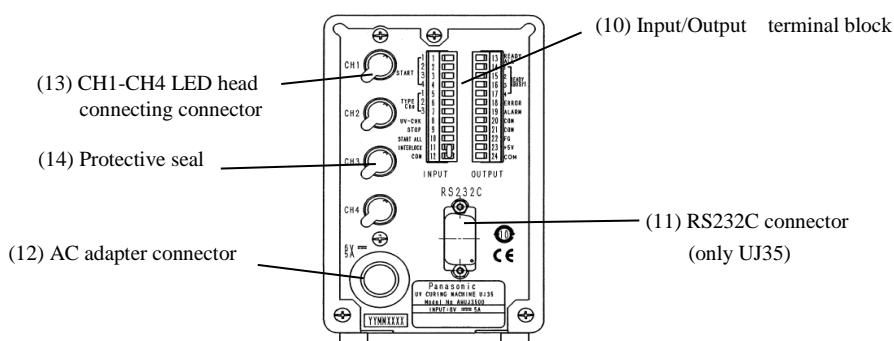

Description	Function	Remark
(1) EMISSION switch	UV is irradiated and stopped by selected irradiating CH head. Red lamp is turned on during UV irradiation.	
(2) READY indicator	Indicates that UV irradiation is enabled (ready to start).	
(3) CH1-CH4 operation switch	Selects the LED head channels for irradiation.	
(4) CH1-CH4 selector/indicator	Red = irradiation, green = standby, yellow = error	
(5) Key operated power switch	Commences/finishes operation of the controller.	
(6) UV sensor connection port	Connects the special UV sensor.	UJ35 only
(7) UV check button	Views/calibrates values measured by the special UV sensor	UJ35 only
(8) Operation unit switch	Specifies irradiation conditions (intensity and time), replacement time settings, and initial values, and switches the display.	
(9) Display unit	Displays irradiation conditions (intensity and time), replacement time settings, head temperature, and initial values.	
(10) Input/output terminal block	Connects a PLC, foot switch, or other external device	
(11) RS232C connector	Connects a PC, PLC, or other external device with RS232C.	UJ35 only
(12) AC adapter connector	Connects the special AC adapter.	
(13) CH1-CH4 head connecting connector	Connects LED heads.	
(14) Protective seal	Protects connectors.	

Install and set up the product according to the following conditions.

### 4.1 Installation conditions

- 1) Ambient temp.: Controller: 0 to +35°C  
Head: +5° to +35°C
- 2) Relative humidity: 30 to 85% (at 25°C, no condensation)
- 3) When setting up the controller, make sure that its rubber feet are horizontally level.
- 4) To prevent damage due to overheating, make sure that the area around the controller is free of any obstructions.
- 5) The dimensions of the controller are 80 mm (L) × 130 mm (H) × 145 mm (D), but remember that the controller will have one or more LED heads attached during use. The radius of the LED head connector cable should be no less than 33 mm, otherwise the cable may become damaged.
- 6) If you find any abnormality, install it so that the power supply can be stopped immediately.

[When using the product]

-Use disconnecting device that complies with IEC60943 or IEC60947

Example : No-fuse circuit breaker , earth leakage circuit breaker.

[When using the product alone]

-Do not install so that it is difficult to pull out the power plug of the AC adapter.

#### Warning

Never place anything on top or below the controller, or obstruct the ventilation openings in any way. Otherwise, overheating and burning may occur.

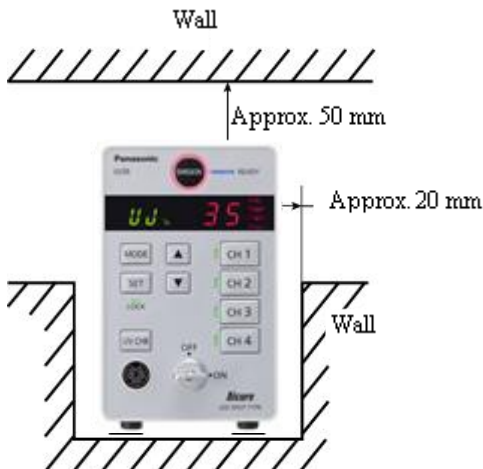

**Ensure that there is enough space above and on the sides of the controller.**

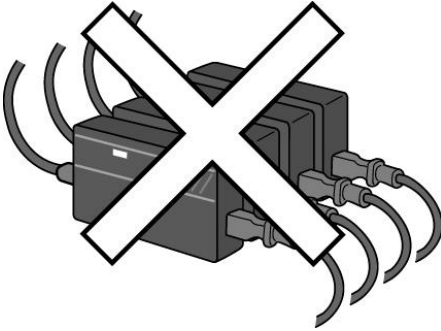

**Warning**

**If using more than one controller, do not bundle the supplied AC adapters together. Otherwise, the AC adapters may overheat and fail.**

## 4.2 General guidelines for irradiation distance and UV intensity

Fix the LED head to a jig at the appropriate distance from the workpiece, according to the size of the area to be irradiated (irradiation diameter) and the required UV intensity.

General guidelines for work distance (WD) and UV intensity are offered below.

### ■ UV intensity data (typical characteristics)

LED head(ANUJ6186)

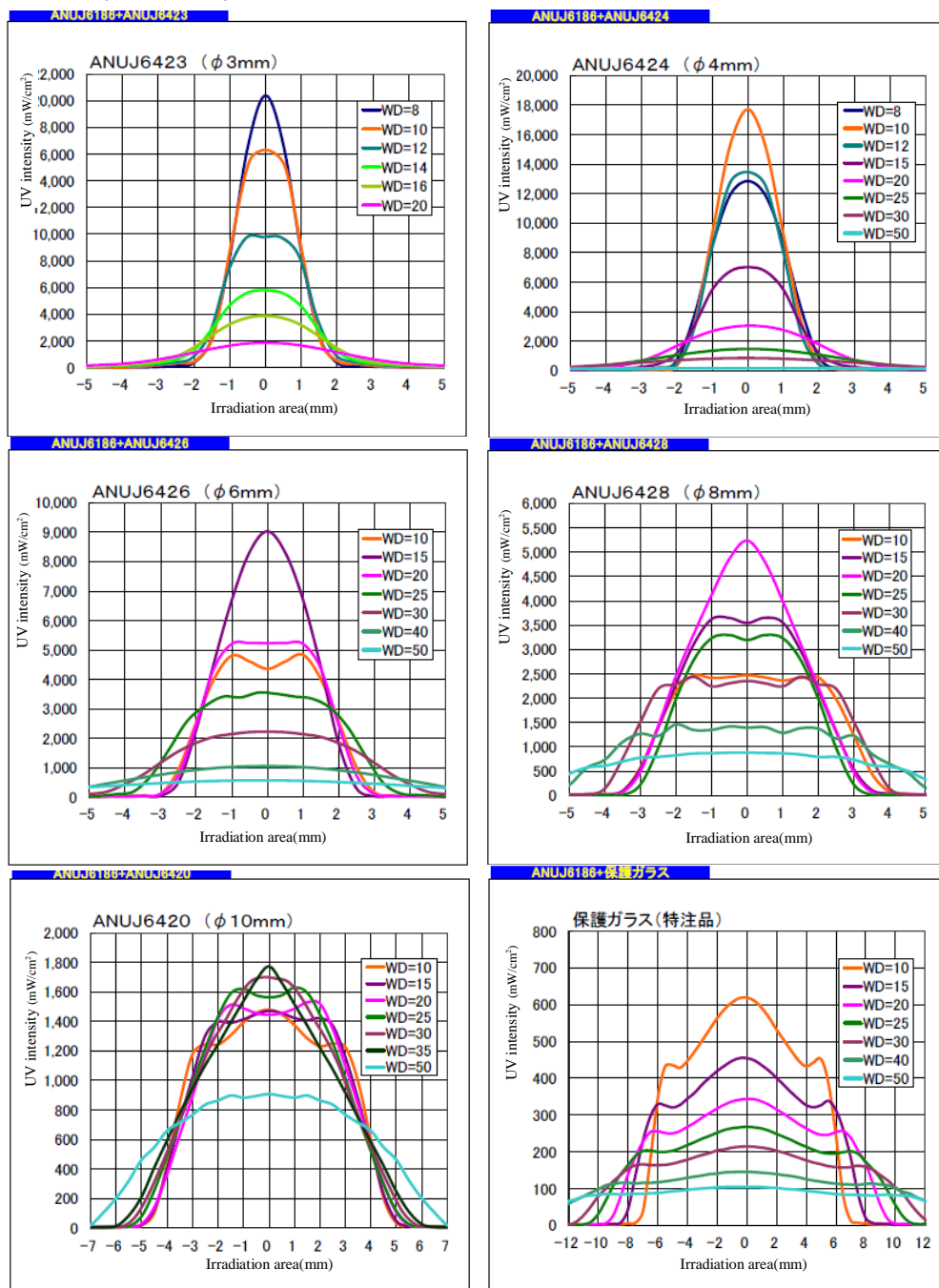

# Installation

## ■ UV intensity data (typical characteristics)

LED head(ANUJ6180)

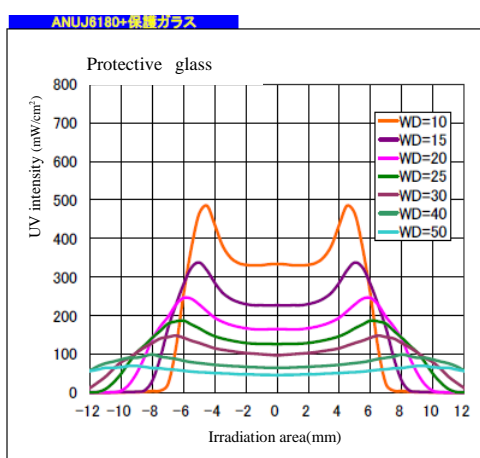
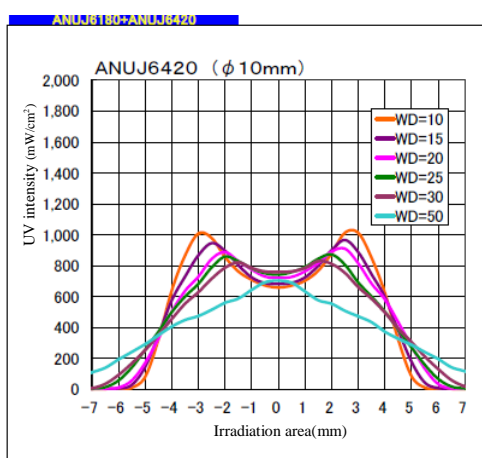
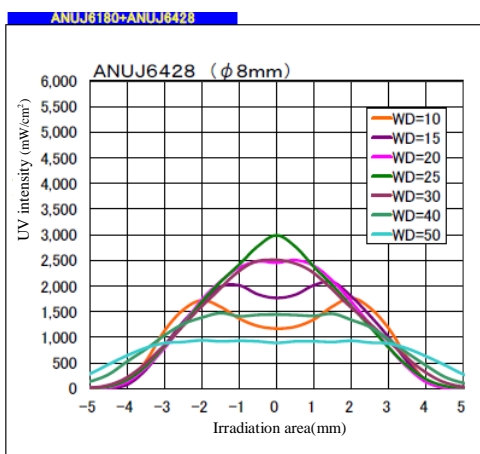
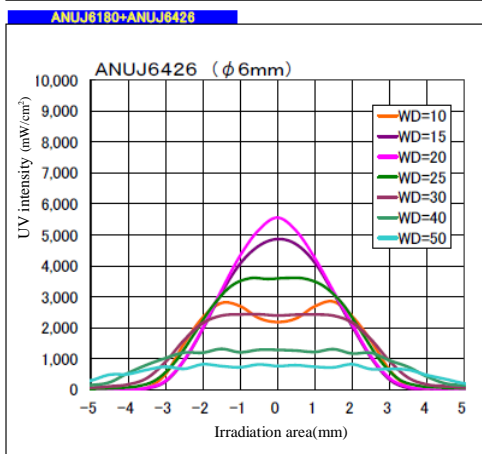
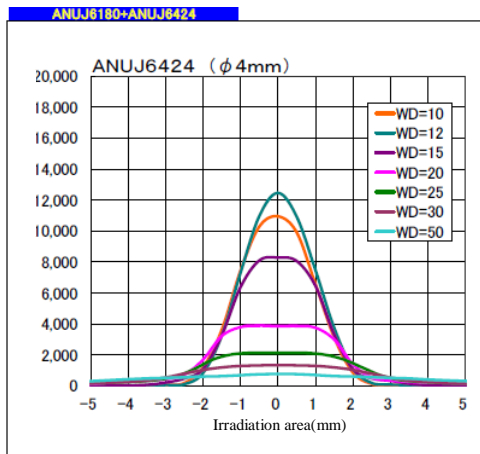
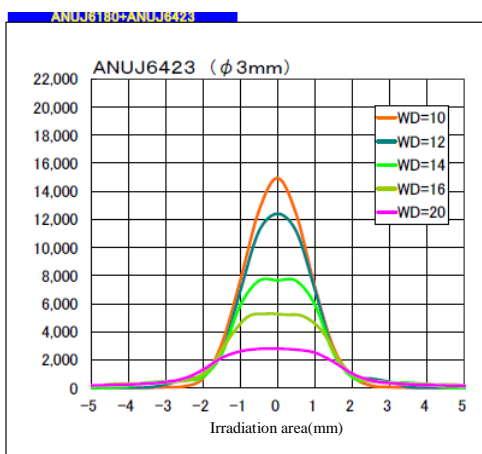

[UV intensity level: 100% Room temperature: 25°C With a cooling device attached]

Please see the website for more information on intensity profiles data.

\* See page 21 for the dimensions of the cooling device.

## 5 Getting started

After connecting the necessary cords, lastly plug in the power cord.  
This section describes the steps up to turning on the power.

### 5.1 Hooking up the connection cable

Plug the connection cable (for the LED head) into its connection port.

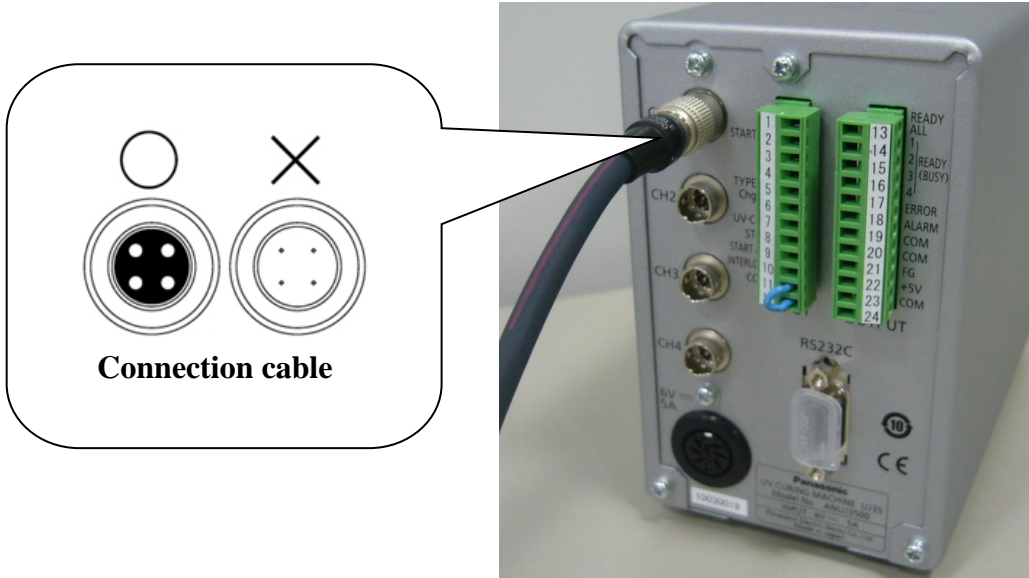

Plug the female side of the connection cable into the main unit. Plugging in the wrong side (the male connector) could bend the connector pins or cause other issues.

### 5.2 Connecting the LED

Connecting the head

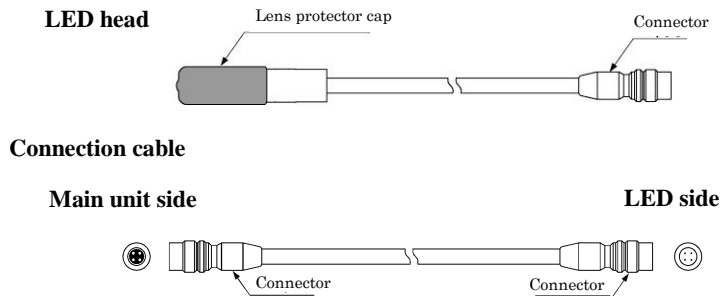

The minimum allowable bend radius for LED head and connection cable is 33 mm.

# Getting started

Rear panel



<Procedure>

1. Plug in the connection cable.
2. Connect the LED head to the connection cable.
3. Remove the protective cap from the LED head.

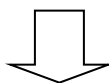

Set the LED jig in place.

<Reference> Heat dissipation device (aluminium)

(A metal fixture attached to the head)

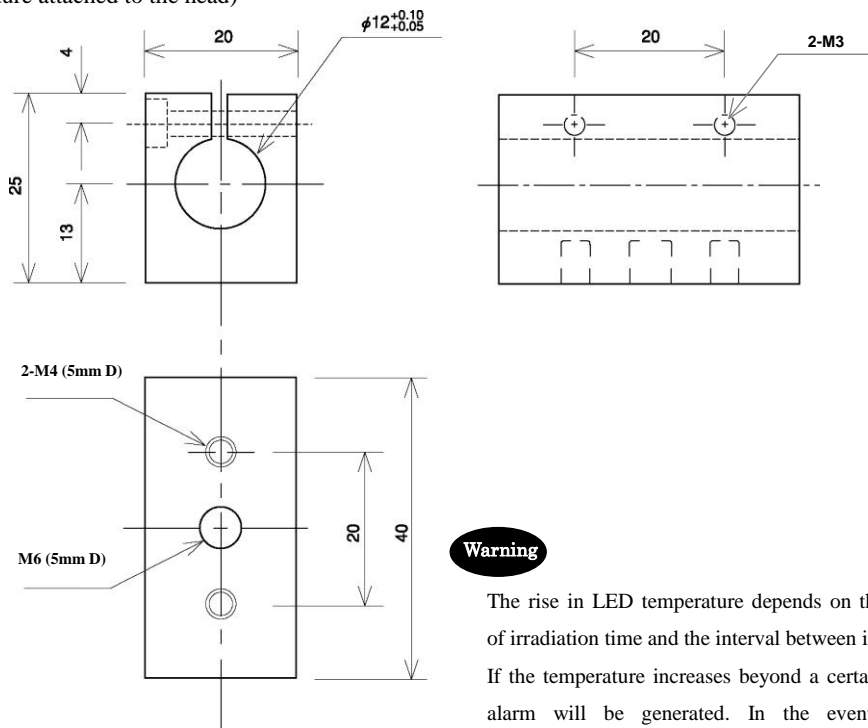

**Warning**

If the LED head is not fixed to a jig, the LED head can become very hot during irradiation. For this reason, do not touch the head directly with your hands during irradiation.

**Attention**

Please tighten the heat dissipation device mounting screws with tightening torque of  $50 \text{ cN} \cdot \text{m} \pm 10\%$  (45 to 55  $\text{cN} \cdot \text{m}$ ).

**Warning**

The rise in LED temperature depends on the duration of irradiation time and the interval between irradiations. If the temperature increases beyond a certain point an alarm will be generated. In the event of such overheating, increase the size of the heat dissipation fixture, or add fins to it.

### 5.3 Connecting the external control signals

The external control connectors on the back of the controller (two blocks of 12 pins) are removable.



External control connectors (12 pin × 2)  
 MINI COMBICON Plug 12P (Phoenix Contact MC 1.5/12-ST-3.5)  
 (Osada OS-85-12P)

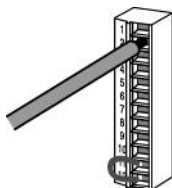

Compatible wire (stranded)

Size	Conductor section area
AWG#24 to 16	0.2 to 1.25 mm <sup>2</sup>

Tightening torque: 0.22 Nm to 0.25 Nm

Cover stripping length

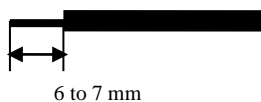

# Getting started

## 5.4 Connecting the AC adapter

Plug the connector of the supplied AC adapter into the AC adapter connector on the rear panel. To ensure that the controller is completely disconnected from the power supply, unplug this connector.

Only connect the power plug end of the AC adapter to a power socket after the controller is fully set up.

**Warning**

The power cable supplied with the ANUJ3000 and ANUJ3500 is Japan PSE standards compatible cable(100V AC).



## 5.5 Power-on operation

To start up the controller, insert the supplied power key into the power key switch and turn it clockwise.

When the power is turned on a beep will sound and the display will indicate startup status. The display will then change to operation mode (under the default setting).



Startup display  
UJ 30/35  
V \* \*\*  
(Version display)



## 6 Operation modes

### 6.1 Operation mode (default mode when power is turned on)

#### ■ Status check



Displays in Operation mode

Display	Descriptions
	EMISSION switch. Pressing it will start irradiation. Stays on during irradiation.
READY	Indicates that irradiation is ready to start. Stays on while irradiation is ready to start. Stays off during irradiation.
CH1~4  	Indicates CH selection and active CH during irradiation. Also indicates temperature warnings and errors. Green: During selection Orange: Temperature warning or error Red: During irradiation The “CH” indicators of 7-seg flash during irradiation.
Green (7-seg) display	UV intensity modulation (0-100%) LED replacement time (0.01-999 × 100 hrs) CH of temp. warning or error (CH1-4) UV intensity setting (“---,” 0.01-49.9 W/cm <sup>2</sup> )
Red (7-seg) display	Irradiation time (Con, 0.00-999 sec.) LED head temp. (0-999TEMP) Cumulative LED use (0-999 × 100 hrs) Error code (E00~E99) UV intensity setting (0.00-49.9 W/cm <sup>2</sup> )
%	Appears when UV intensity modulation is displayed
sec	Appears when irradiation time is displayed
TEMP	Appears when LED temperature is displayed
×100hrs	Appears when LED replacement time and cumulative LED use are displayed
W/cm <sup>2</sup>	Appears when UV intensity is displayed
LOCK	Settings are locked (no changes can be made)

# Operation modes

## ■ How to operate the controller

### 1) Setting irradiation conditions

Setting the irradiation intensity and irradiation time separately for each of CH1 to CH4.

☞ **The displayed values apply to the flashing channel.**

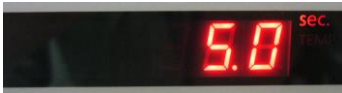
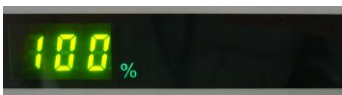

#### 1. Selecting channels

Select the channel to be set by pressing CH1 to CH4. The selected channel is indicated by a green light (flashing or still).

\* It is not possible to select a CH unless an LED head is connected to it.

#### 2. Setting irradiation intensity

Hold down the SET switch to select the CH to be set. (The selected channel is indicated by a green light.) Initially, only “%” (intensity) appears in the green (7-seg) display. Use  $\Delta/\nabla$  to set the desired intensity value, then press SET again to confirm. Note that while setting the irradiation intensity you can press the EMISSION switch to start UV irradiation. This makes it easy to make adjustments.

#### 3. Setting irradiation time

When you have finished setting the intensity, the green display will automatically display only “sec.” Use  $\Delta/\nabla$  to set the desired time value, then press the SET switch again to confirm. Note that if you use  $\nabla$  to decrease the setting below “0.0 sec” the display will show “Con.” At this setting irradiation will be continuous with no time limit.

#### 4. Completing settings

After setting irradiation time and pressing SET the controller will return to Operation mode. To continue settings for other channels, repeat the procedure above from step 1 for each channel you wish to set.

(It is possible to switch the display even during irradiation. The displayed values are stored in memory even when the controller is powered off. After the controller is powered on again it will restore the display to its last state. Note, however, that unless a channel is selected nothing will be appeared on the display.)

### 2) Timer irradiation

Irradiation using the EMISSION switch of the controller

☞ **The displayed values apply to the flashing channel.**

#### (1) Starting irradiation



1. Select the channel/s for irradiation.

2. Press the EMISSION switch

(Irradiation will start on all the active channels (green indicator).

The EMISSION switch glows red during irradiation.)

\* Irradiation stops after irradiation is finished on all ch

#### (2) Stopping irradiation

3. While irradiation is in progress press the EMISSION switch again.

(Irradiation will stop on all channels.)

## 3) Continuous irradiation

Irradiation using the EMISSION switch of the controller

**The displayed values apply to the flashing channel.**

### (1) Starting irradiation



1. Select the channel/s for irradiation.

2. Press the EMISSION switch

(Irradiation will start on all channels indicated by red lights. The EMISSION switch glows red during irradiation.)

### (2) Stopping irradiation

3. While irradiation is in progress press the EMISSION switch again. (Irradiation will stop on all channels.)

## 4) Irradiation using an external start signal

Irradiation can be started externally using the INPUT terminals on the rear of the controller—either “START ALL” or “START1-4.”

### (1) Starting irradiation

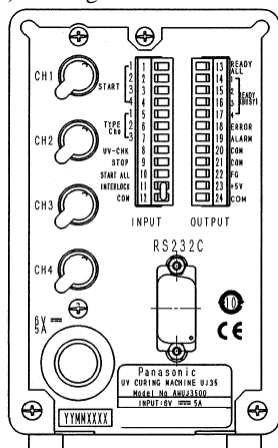

1. Turn on the START signal.

(Irradiation is activated under the conditions summarized below.)

Start signal setting	INPUT terminal	
	START ALL	START1-4
PULSE	○	○
STATUS	●	●

○···Irradiation starts when the start signal is switched from OFF to ON. (Duration is per timer setting.)

●···Irradiation starts when the start signal is switched from OFF to ON, and stops with an OFF signal (at “Con” setting)

Case of START ALL: When the START ALL signal is turned ON irradiation starts simultaneously on all selected channels.

Case of START1-4: When the signal of a START No. terminal is switched ON irradiation starts on the corresponding CH No.

### (2) Stopping irradiation

2. Switch the STOP signal to ON.

(Irradiation can also be stopped by pressing the EMISSION switch.)

# Operation modes

## 5) Display of head management information



[Head temperature (°C or °F)]

1. With the display showing irradiation information, press the MODE switch.
  2. The head temperature is displayed.
- \* Fahrenheit values include a "." (decimal point).
3. Press the CH switch to switch to other channels.



[Display of head lifetime information]

1. With the display showing head temperature, press the MODE switch.
2. The display shows the lifetime setting (green) and cumulative irradiation time (red).
3. Press the CH switch to switch to other channels.
4. Press the MODE switch to return to display of irradiation information.



[Resetting head lifetime and cumulative irradiation time values]

1. With the display showing the lifetime setting (green) and cumulative irradiation time (red), hold down the SET switch.
2. The lifetime setting (green) will be displayed.
3. Use  $\Delta/\nabla$  to change the lifetime setting.
4. Press the SET switch.
5. The cumulative irradiation time is displayed (red).
6. Hold down  $\Delta/\nabla$  to reset the value to 0.
7. Press the CH switch to switch to other channels.
8. Press the MODE switch to return to display of irradiation information.

\* To cancel a change, press the MODE switch. The display will return to showing irradiation information, and the change will be lost from memory.

- If you are using an LED head with other controllers, it is possible to input the cumulative irradiation time via a serial data connection. This makes it possible to effectively manage the lifetime of the head.

## 6) Panel lock function

This function allows all the settings of the controller's front panel to be locked.



1. In operation mode, hold down  $\Delta/\nabla$ . The settings will become locked and the "LOCK" indicator will light up.
2. To unlock the settings, hold down  $\Delta/\nabla$  again.

[Locked settings]

- Irradiation intensity
- Irradiation time
- Head lifetime
- UV intensity
- CH selection/deselection

## 6.2 UV measurement and Calibration mode

It is possible to make UV measurements and Calibrations.

\* To use this mode it is necessary to have a compatible UV sensor (option).

### ■ Connection



1. Please connect the extension cable to the UV sensor connection port.

※ When you are connecting or disconnecting the cable to the UV sensor (or UV sensor connection port), please unplug the connector horizontally.

### ■ Operation

1) Measuring UV intensity

(1) Connecting a UV sensor



1. While in operation mode, press the UV CHK switch.
2. The intensity setting value (green) and intensity measurement value (red) will be displayed.
3. Select the CH for UV intensity measurement.
4. While the intensity setting value (green) and intensity measurement value (red) are displayed, hold down the SET switch.
5. The intensity setting value (green) is displayed.
6. Use  $\Delta/\nabla$  to change the intensity setting value to “---.”
7. Press the SET switch.
8. The intensity setting value (green) and intensity measurement value (red) are displayed.
9. Press the EMISSION switch to start irradiation and begin the UV intensity measurement. The irradiation modulation (%) and measured intensity value (W/cm<sup>2</sup>) are displayed.
10. Press EMISSION again to stop irradiation.

\* Press the MODE switch to switch the measurement range. (0.00 range/00.0 range)

\* If a measured value exceeds the measurement range the display value will start flashing.

(2) Making a UV measurement



\* It is possible to change the irradiation modulation (%) during a UV intensity measurement, using  $\Delta/\nabla$ .



# Operation modes

## 2) Calibration

### (1) Switching to calibration mode



1. While in operation mode, press the UV CHK switch.
2. The intensity setting value (green) and intensity measurement value value (red) are displayed.
3. Select the CH for UV intensity measurement.
4. While the intensity setting value (green) and intensity measurement value (red) are displayed, hold down the SET switch.
5. The intensity measurement value (green) is displayed.
6. Use  $\Delta/\nabla$  to change the intensity setting to the desired value.
7. Press the SET switch.
8. The intensity measurement value (red) is displayed.
9. Press the SET switch.
10. The intensity setting value (green) and intensity measurement value (red) are displayed.
11. Press the EMISSION switch to start irradiation and begin calibration.  
When calibration is completed, irradiation will automatically stop.

### (2) Starting Calibration



\* If the EMISSION switch is pressed during Calibration, irradiation will stop and an error will be generated.



## 6.3 Default settings mode

This mode is used for the units (°C/°F) for head temperature readings, for switching between READY/BUSY signal, and for setting the buzzer ON/OFF.

\* The default values are Celsius (°C) for temperature display, BUSY, and buzzer ON.

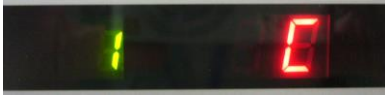

[Default settings mode]

1. While pressing down the MODE switch power ON the controller.
2. When the display starts up 1 C/F is displayed.



[Switching between °C/°F display]

1. Use  $\Delta/\nabla$  to switch between °C (Celsius)/°F (Fahrenheit).
2. Press the SET switch. 2 A/b will be displayed.



[Switching between READY/BUSY signal]

1. Use  $\Delta/\nabla$  to switch between A=READY/b=BUSY.
2. Press the SET switch. 3 On/OFF will be displayed.

[Switching the buzzer ON/OFF]

1. Use  $\Delta/\nabla$  to switch between buzzer ON/OFF.
2. Press the SET switch. 1 C/F will be displayed.

[Exiting from default settings mode]

1. Hold down the SET switch to switch to operation mode.



[Restoring default settings

(all settings are restored to their initial default values)]

1. While in default settings mode, press the MODE switch.
2. EE ||| will be displayed.
3. Hold down  $\Delta/\nabla$ .
4.   will be displayed.
5. Hold down SET. EE will be displayed. When EE CLR appears all settings have been restored to their original default values, and the controller returns to operation mode.



# Operation modes

## 6.4 Timing chart

### 1) Batch irradiation:

Heads selected <sup>(\*)</sup> with CH1 through 4 operation button in front of the controller are processed in batch irradiation mode.

- Preparation of batch irradiation: READY All is ON<sup>(\*)</sup>.
- Batch irradiation start: Press EMISSION button in front of the controller or turn on START ALL input signal on the backside.
- Batch stop: Press EMISSION button during irradiation or turn on STOP input on the backside.

#### ① Batch timer irradiation

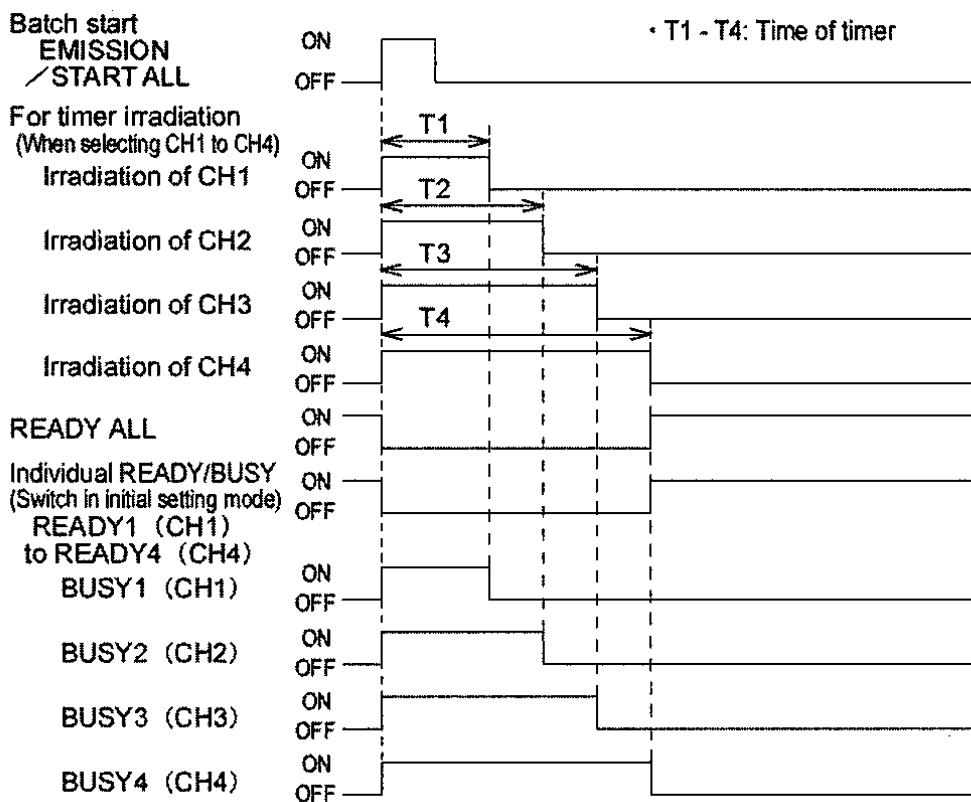

② Continuous (Con) batch irradiation

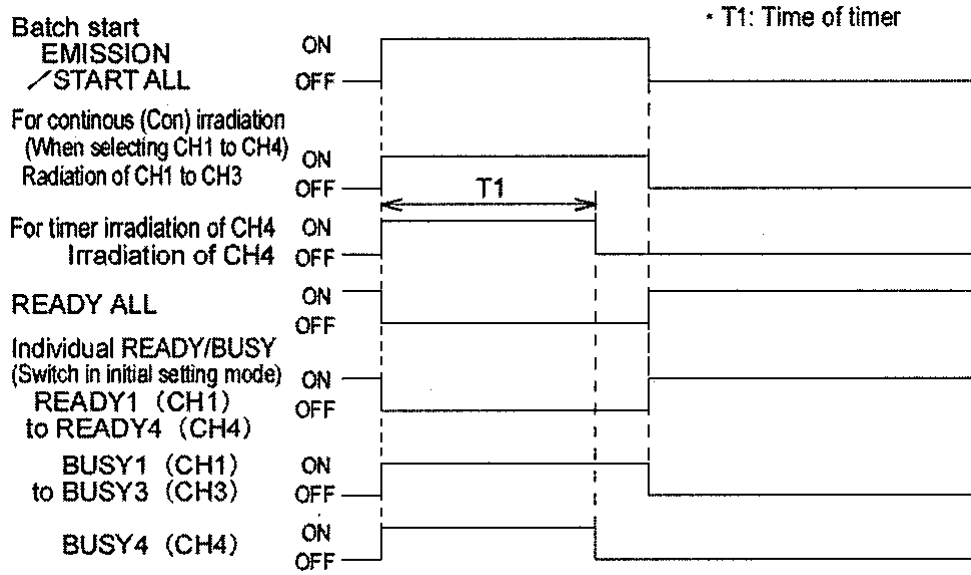

# Operation modes

## 2) Individual irradiation

When START 1~4 input on the backside of the controller is turned on, individual CH is irradiated.

- Preparation of individual irradiation: READY 1~4 applicable to each CH is ON\*2)
- Individual start: Turn on START 1~4 input signals on the backside of the controller.
- Batch stop: Press EMISSION button during irradiation or turn on STOP input on the backside.

### ① Individual timer irradiation

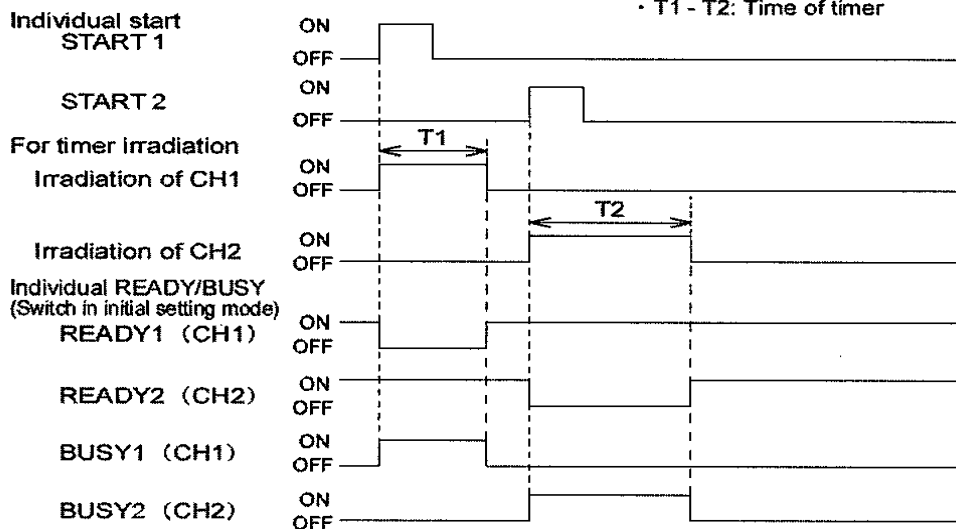

### ② Continuous (Con) individual irradiation

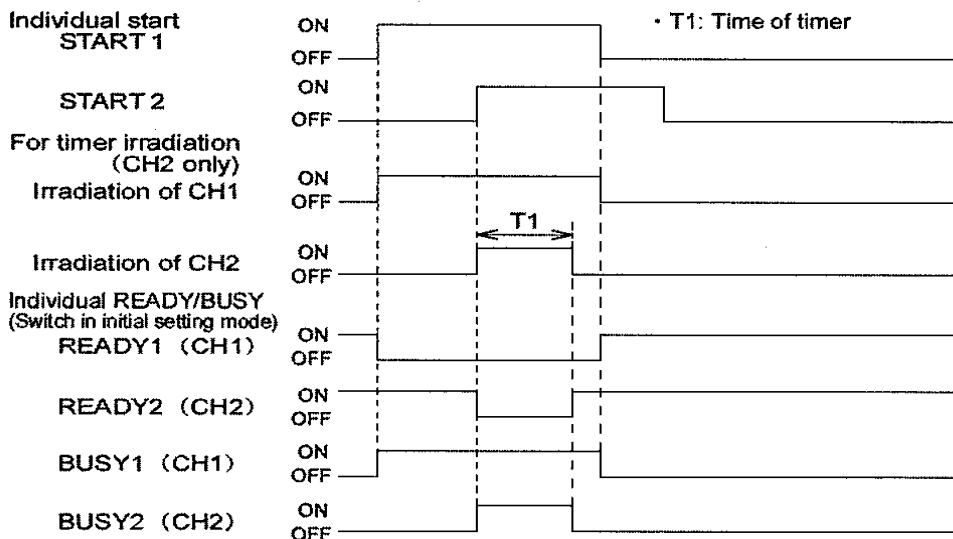

\*1) It is not possible to select a particular channel unless it has an LED head connected to it.

\*2) Conditions under which the signals below are set to ON.

- READY ALL: ON when CHs are selected on the front panel of the controller, and all selected channels are ready\*3) for irradiation.
- READY1-4: ON when the corresponding CH is ready for irradiation. Note that even if the CH is not selected on the front of the controller, if the channel is ready\*3) for irradiation, the signal will be ON.
- BUSY1-4: ON while irradiation is in progress on the corresponding channel.

\*3) Irradiation-ready state

- The INTERLOCK input on the rear of the controller is set to ON.
- Irradiation conditions (intensity and time) have been set, and the 1STEP time value is not set to 0.

## 7.1 External input/output control

■ External control connectors (12 pin × 2)

MINI COMBICON Plug 12P

(PHOENIX CONTACT: MC 1.5/12-ST-3.5)

(Osada: OS-85-12P)

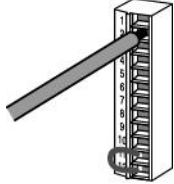

Compatible wiring (stranded)

Size	Conductor section area
AWG#24-16	0.2 - 1.25 mm <sup>2</sup>

**Warning**

Tightening torque: 0.22 to 0.25 Nm

Precautions for wiring

- Carefully strip the cover so as not to damage the core wires.
- Connect the core wires without twisting them.
- Connect the core wires without soldering them; otherwise, they may break due to vibration.
- After connection, do not apply stress to the cable.
- Because of the terminal structure, if the wire is tightened by a counterclockwise rotation, the connection will fail. In such cases, pull out the wire, check the terminal hole, and then connect it again.

■ Input/output terminal table

**INPUT**

Pin No	Signal name	Description	
1	START 1	CH1 irradiation start signal	
2	START 2	CH2 irradiation start signal	
3	START 3	CH3 irradiation start signal	
4	START 4	CH4 irradiation start signal	
5	TYPE Chg1	Product type switching signal	UJ35 only
6	TYPE Chg2	Product type switching signal	
7	TYPE Chg3	Product type switching signal	
8	UV CHECK	UV intensity control mode signal	
9	STOP	Irradiation stop signal, Error reset	
10	START ALL	CH1-CH4 irradiation start signal	
11	INTERLOCK	Interlock (normally ON)	
12	COM	Common terminal for input/output signals	

**OUTPUT**

Pin No	Signal name	Description	
13	READY ALL	ON when irradiation is ready to start	READY/BUSY signal is changed over by changing the initial setting mode.
14	READY1/BUSY1	ON when CH1 irradiation is ready to start/in progress	
15	READY2/BUSY2	ON when CH2 irradiation is ready to start/in progress	
16	READY3/BUSY3	ON when CH3 irradiation is ready to start/in progress	
17	READY4/BUSY4	ON when CH4 irradiation is ready to start/in progress	
18	ERROR	Error signal	
19	ALARM	Warning signal (temperature/time warning)	
20	COM	Common terminal for input/output signals	
21	COM	Common terminal for input/output signals	
22	FG	Frame gland	
23	+5V	5 V DC output (for display or output signals)	
24	COM	Common terminal for input/output signals	

\* Pin Nos. 12, 20, 21 and 24 are connected internally.

**Warning**

The ON time of input signal pulses must be 100 ms or more.

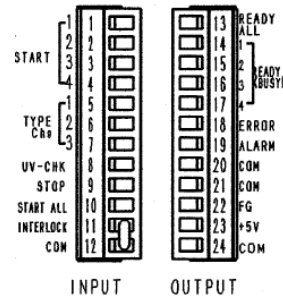

Wire stripping length

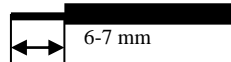

## Product type switching table

Type No.	Pin No.7	Pin No.6	Pin No.5	Remark
0	OFF	OFF	OFF	Product type switching is enabled when all pins are off.  When an external signal is on, the product type set by the external signal has priority.  * The green display will show a flashing “.” (period). Irradiation intensity and irradiation time settings cannot be performed using the controller.
1	OFF	OFF	ON	
2	OFF	ON	OFF	
3	OFF	ON	ON	
4	ON	OFF	OFF	
5	ON	OFF	ON	
6	ON	ON	OFF	
7	ON	ON	ON	

## Operation via external signals

### Input

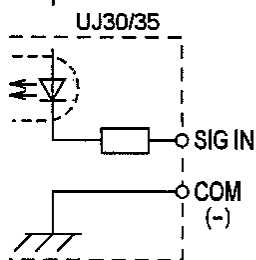

No-voltage input from equipment such as open collector (Tr) and relay

### Contact input

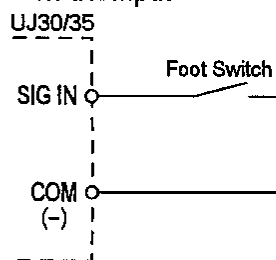

### Non-contact input

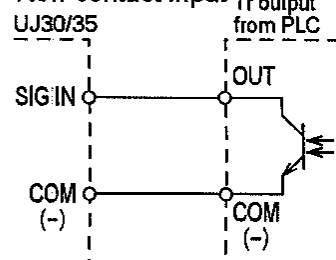

### Output

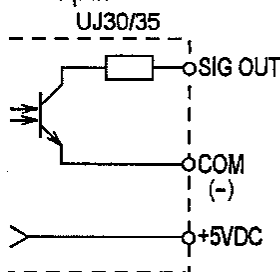

Rated operational voltage: 5 to 24 V DC  
Output capacity: 100 mA (Max)

### External power supply

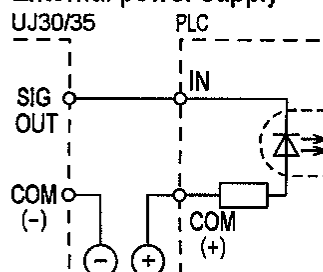

### Internal power supply

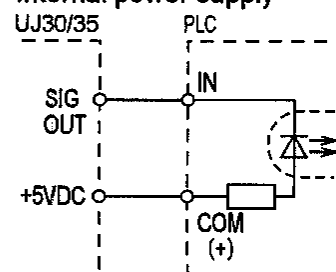

### Output Specification

- Rated load voltage: 5 V DC to 28 V DC
- Max. load current: 100 mA (per 1 output)  
When 5 V internal voltage is used, set the total of maximum load current to less than 250mA.
- Maximum voltage drop is less than 0.9 V when output is given.

# External control

## 7.2 Serial communication control

### ■ RS-232C terminal specifications

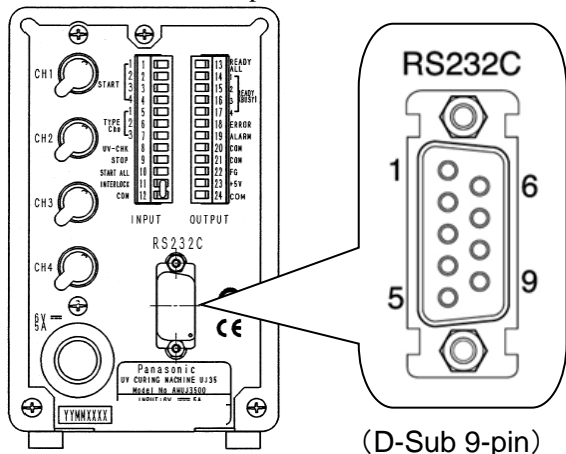

(D-Sub 9-pin)

D-sub 9-pin connector (male pins) (JAE: DELC-J9PAF-10L9E)

[Connection cable specifications]

For the cable connector use a D-sub 9-pin connector (female pins).

Cable (shielded).

UJ30/35 Controller side

Signal	Name	Pin No.
Unconnected	—	1
Send data	SD	2
Receive data	RD	3
Unconnected	—	4
Signal ground	SG	5
Unconnected	—	6
Unconnected	—	7
Unconnected	—	8
Unconnected	—	9

Pin No.	Name	Signal
1	—	Unconnected
2	RD	Send data
3	SD	Receive data
4	—	Unconnected
5	SG	Signal ground
6	—	Unconnected
7	—	Unconnected
8	—	Unconnected
9	—	Unconnected

### ■ Communication specifications

Interface	RS232C
Communication method	Half duplex
Synchronization	Asynchronous communication method
Transmission medium	3-core shielded wire
Transmission distance	15 m max.
Transmission speed	38400bps
Transmission code	ASCII
Transmission format	Data length: 8 bits
	Parity check: None
	Stop bit: 1 bit

## ■ Commands and responses

- Instructions sent to the controller are called commands.
- Messages returned from the controller are called responses.
- The communications are two-way. (When a command is sent, a response is always returned.)
- Data is sent in ASCII format.

### Warning

- When a response is not received, this indicates that the transmission format is wrong, the command has not yet reached its destination, or the controller is not in operation. Check the communication specifications, such as the transmission speed, data lengths, and parity.
- When a response with “!” instead of “\$” stored is received, it indicates that the command has not been processed correctly. Check the communication error code stored in the response to identify the error.

## ■ Command/response format

### Command message

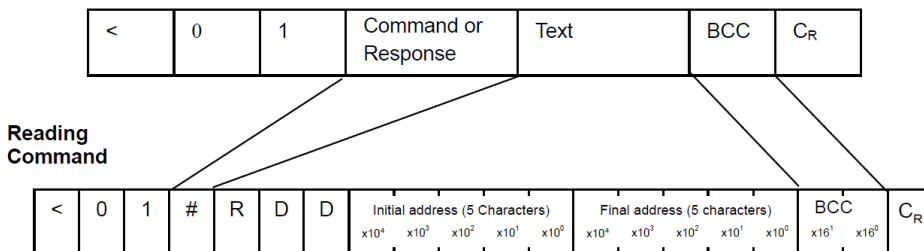

### Normal response

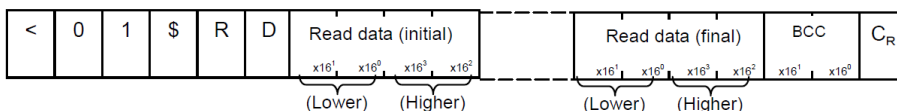

### Error response

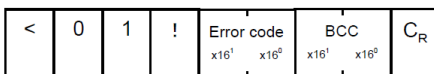

## ■ Block check code BCC (H) (L)

Binary hexadecimal 00-FF (ASCII-encoded)

- To improve the reliability of transmission data, this encoding enables error detection using longitudinal parity bits. However, if “\*\*\*” appears instead of BCCs, transmission is possible without BCCs. Even in this case, however, BCCs will be included in the response.
- BCCs are created by taking the exclusive OR from the header (<) to the final character of the text, and then encoding this 8-bit word into a 2-character ASCII code.

# External control

## ■ Control commands

Name	Character	ASCII	Descriptions
Header	<	3CH	Beginning of the message
Command	#	23H	Command message
Response (Normal)	\$	24H	Normal response message
Response (Error)	!	21H	Error response message
Terminator	C <sub>R</sub>	0DH	End of the message

## ■ Support commands

An instruction for the controller is called a “command,” while the message sent back from the controller is a “response.” The commands below marked by ○ are supported.

If an unsupported command is received by the controller it returns an error response including a “NOT supported error” code.

No.	Command name	Code	Description	Support
1	Data area read	RD	Reading from data area	○
2	Data area write	WD	Writing to data area	○

## ■ Error codes

Binary hexadecimal 00-FF (ASCII-encoded)

- Description of generated errors

Error code	Error name	Descriptions and troubleshooting
40H	BCC error	The command data caused a BCC error. <Troubleshooting> Check the BCC code and resend the data.
41H	Format error	For example, the transmission format of the command data is not correct, or the address does not exist. <Troubleshooting> Correct the format or command.
42H	NOT supported error	The sent address was outside the range. <Troubleshooting> Check the address.
45H	Address error	The sent address was outside the range. <Troubleshooting> Check the address.

## ■ Data areas

### [WD] Write data area

This writes the contents of the data area.

#### To write the contents of DT

##### Command

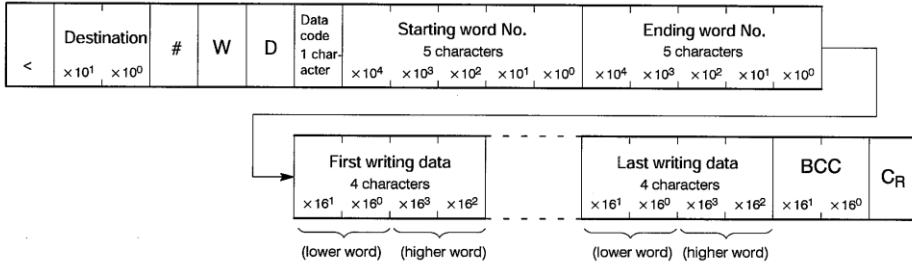

##### Normal response (Write successful)

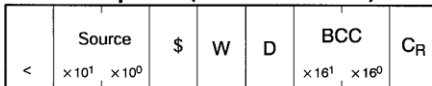

##### Error response (Write error)

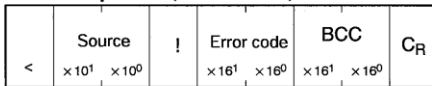

##### Data code

Data	Notation
Data register	DT

### [RD] Read data area

This reads the contents of the data area.

#### To read the contents of DT

##### Command

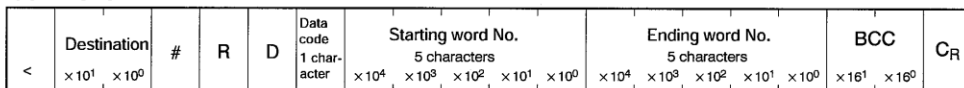

##### Normal response (Read successful)

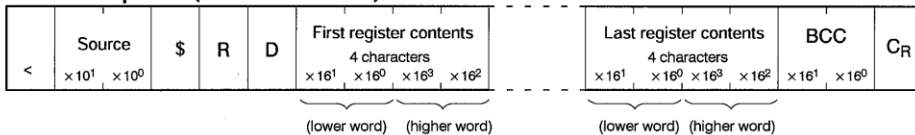

##### Error response (Read error)

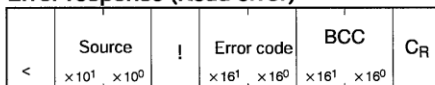

##### Data code

Data	Notation
Data register	DT

# External control

## 7.3 Communications address map

■ Address for reading (1 address = 16 bits)

Address	ON bits	Name	Data	Description
05000		LED1 total irradiation time (higher byte)	0-999000	Current total irradiation time for CH1 (units: 0.1 hr, 1=0.1 hr)
05001		LED1 total irradiation time (lower byte)		
05002		LED2 total irradiation time (higher byte)	0-999000	Current total irradiation time for CH2 (units: 0.1 hr, 1=0.1 hr)
05003		LED2 total irradiation time (lower byte)		
05004		LED3 total irradiation time (higher byte)	0-999000	Current total irradiation time for CH3 (units: 0.1 hr, 1=0.1 hr)
05005		LED3 total irradiation time (lower byte)		
05006		LED4 total irradiation time (higher byte)	0-999000	Current total irradiation time for CH4 (units: 0.1 hr, 1=0.1 hr)
05007		LED4 total irradiation time (lower byte)		
05010		Current selection product type	0-7	Displays product type (0-7)
05019		UV CHK switching	0,1	1: UV-CHK mode
05020		Current UV sensor measurement	0-9990,10000	UV intensity readings during UV measurement and TYPE0 calibration (0-9990 (>0.01) W/cm <sup>2</sup> , 10,000=overrange) (The UV values are retained only after completion of calibration, not during measurement.)
05021		Calibration in progress	0,1	1: Calibration in progress
05022		Calibration complete	0,1	1: Calibration complete (reset by starting a calibration)
05023		Modulation during calibration	0-100	Modulation (%) of TYPE0 during calibration (reset by starting a calibration)
05024		Current UV measurement range	0,1	0: LOW range (0.00-9.99), 1: HIGH range (0.0-50.0)
05025		Interlock "1": ON	0,1	0: Interlock OFF, 1: Interlock ON
05030		LED1 warning temperature level	0-500	Warning temperature level (°C/°F) × 0.1 (°10° = 1.0°C)
05031		LED2 warning temperature level	0-500	
05032		LED3 warning temperature level	0-500	
05033		LED4 warning temperature level	0-500	
05035		LED1 remaining time before replacement	0-65535	Remaining time before LED replacement (units: hr, 1 = 1 hr)
05036		LED2 remaining time before replacement	0-65535	
05037		LED3 remaining time before replacement	0-65535	
05038		LED4 remaining time before replacement	0-65535	
05060	0	LED1 connecting	-	For each bit, "0" = not connected, "1" = connected. (if LED1 is connecting: 1, if LED2 is connecting: 2) (if LED3 is connecting: 4, if LED4 is connecting: 8)
	1	LED2 connecting	-	
	2	LED3 connecting	-	
	3	LED4 connecting	-	
	4	LED1 irradiating	-	For each bit, "0" = not irradiating, "1" = irradiating
	5	LED2 irradiating	-	
	6	LED3 irradiating	-	
	7	LED4 irradiating	-	
05061	8	UV-CHK mode measurement in progress	-	For each bit, "1" = signal output is ON
	9	READY ALL	-	
	10	ERROR	-	
	11	ALARM	-	
	12	ALARM	-	
05062	0	LED1 temperature warning	-	For each bit, "1" = temperature warning is active.
	1	LED2 temperature warning	-	
	2	LED3 temperature warning	-	
	3	LED4 temperature warning	-	
	4	LED1 operation time warning	-	For each bit, "1" = time warning is active.
	5	LED2 operation time warning	-	
	6	LED3 operation time warning	-	
	7	LED4 operation time warning	-	
05063	0	LED1 connection error	-	[E10] For each bit, "1" = error has occurred
	1	LED2 connection error	-	
	2	LED3 connection error	-	
	3	LED4 connection error	-	
	4	LED4 connection error	-	[E40] For each bit, "1" = error has occurred.
	5	LED3 temperature error	-	
	6	LED2 temperature error	-	
	7	LED1 temperature error	-	
	8	LED1 operation time error	-	[E50] For each bit, "1" = error has occurred.
	9	LED2 operation time error	-	
	10	LED3 operation time error	-	
	11	LED4 operation time error	-	
05064	0	LED1 emergency stop error	-	[E00] For each bit, "1" = error has occurred.
	1	LED2 emergency stop error	-	
	2	LED3 emergency stop error	-	
	3	LED4 emergency stop error	-	
	4	LED1 short-circuit error	-	[E30] For each bit, "1" = error has occurred.
	5	LED2 short-circuit error	-	
	6	LED3 short-circuit error	-	
	7	LED4 short-circuit error	-	
	8	LED1 open circuit error	-	[E20] For each bit, "1" = error has occurred.
	9	LED2 open circuit error	-	
	10	LED3 open circuit error	-	
	11	LED4 open circuit error	-	
	12	LED1 calibration error	-	TYPE0 [E60] For each bit, "1" = error has occurred.
	13	LED2 calibration error	-	
	14	LED3 calibration error	-	
	15	LED4 calibration error	-	

# External control

Address	ON bits	Name	Data	Description
05070		Current LED1 temperature	0-2120	0-999 Celsius/Fahrenheit (*C/*F) ×0.1
05071		Current LED2 temperature	0-2120	
05072		Current LED3 temperature	0-2120	
05073		Current LED4 temperature	0-2120	
05075		Current LED1 step	0-10	STEP1-10 Return to current STEP
05076		Current LED2 step	0-10	
05077		Current LED3 step	0-10	
05078		Current LED4 step	0-10	
05080		Current LED1 elapsed time (displayed)	0-65535	Displays elapsed time during irradiation in real time (×0.1s)
05081		Current LED2 elapsed time (displayed)	0-65535	
05082		Current LED3 elapsed time (displayed)	0-65535	
05083		Current LED4 elapsed time (displayed)	0-65535	
05092		Current LED1 UV intensity	0-100	Displays current intensity during irradiation (0-100%)
05093		Current LED2 UV intensity	0-100	
05094		Current LED3 UV intensity	0-100	
05095		Current LED4 UV intensity	0-100	
05100		LED1 is selection (CH1)	0,1	For each bit, "0" = not selected, "1" = selected.
05101		LED2 is selection (CH2)	0,1	
05102		LED3 is selection (CH3)	0,1	
05103		LED4 is selection (CH4)	0,1	
05104		Type 0 LED1 intensity	0-100	0-100%
05105		Type 0 LED1 time	1-9990,9999	0.1-999 SEC, 9999 = continuous irradiation
05106		Type 0 LED2 intensity	0-100	0-100%
05107		Type 0 LED2 time	1-9990,9999	0.1-999 SEC, 9999 = continuous irradiation
05108		Type 0 LED3 intensity	0-100	0-100%
05109		Type 0 LED3 time	1-9990,9999	0.1-999 SEC, 9999 = continuous irradiation
05110		Type 0 LED4 intensity	0-100	0-100%
05111		Type 0 LED4 time	1-9990,9999	0.1-999 SEC, 9999 = continuous irradiation
05124		Type 1 LED1 STEP1 intensity	0-100	0-100%
05125		Type 1 LED1 STEP1 time	1-9990,9999	0.1-999 SEC, 9999 = continuous irradiation
§		§	§	§
05142		Type 1 LED1 STEP10 intensity	0-100	0-100%
05143		Type 1 LED1 STEP10 time	1-9990,9999	0.1-999 SEC, 9999 = continuous irradiation
05144		Type 1 LED2 STEP1 intensity	0-100	0-100%
05145		Type 1 LED2 STEP1 time	1-9990,9999	0.1-999 SEC, 9999 = continuous irradiation
§		§	§	§
05162		Type 1 LED2 STEP10 intensity	0-100	0-100%
05163		Type 1 LED2 STEP10 time	1-9990,9999	0.1-999 SEC, 9999 = continuous irradiation
05164		Type 1 LED3 STEP1 intensity	0-100	0-100%
05165		Type 1 LED3 STEP1 time	1-9990,9999	0.1-999 SEC, 9999 = continuous irradiation.
§		§	§	§
05182		Type 1 LED3 STEP10 intensity	0-100	0-100%
05183		Type 1 LED3 STEP10 time	1-9990,9999	0.1-999 SEC, 9999 = continuous irradiation
05184		Type 1 LED4 STEP1 intensity	0-100	0-100%
05185		Type 1 LED4 STEP1 time	1-9990,9999	0.1-999 SEC, 9999 = continuous irradiation.
§		§	§	§
05202		Type 1 LED4 STEP10 intensity	0-100	0-100%
05203		Type 1 LED4 STEP10 time	1-9990,9999	0.1-999 SEC, 9999 = continuous irradiation
05214		Type 2 LED1 STEP1 intensity	0-100	0-100%
05215		Type 2 LED1 STEP1 time	1-9990,9999	0.1-999 SEC, 9999 = continuous irradiation
§		§	§	§
05232		Type 2 LED1 STEP10 intensity	0-100	0-100%
05233		Type 2 LED1 STEP10 time	1-9990,9999	0.1-999 SEC, 9999 = continuous irradiation
05234		Type 2 LED2 STEP1 intensity	0-100	0-100%
05235		Type 2 LED2 STEP1 time	1-9990,9999	0.1-999 SEC, 9999 = continuous irradiation
§		§	§	§
05252		Type 2 LED1 STEP10 intensity	0-100	0-100%
05253		Type 2 LED1 STEP10 time	1-9990,9999	0.1-999 SEC, 9999 = continuous irradiation
05254		Type 2 LED2 STEP1 intensity	0-100	0-100%
05255		Type 2 LED2 STEP1 time	1-9990,9999	0.1-999 SEC, 9999 = continuous irradiation
§		§	§	§
05272		Type 2 LED3 STEP10 intensity	0-100	0-100%
05273		Type 2 LED3 STEP10 time	1-9990,9999	0.1-999 SEC, 9999 = continuous irradiation
05274		Type 2 LED4 STEP1 intensity	0-100	0-100%
05275		Type 2 LED4 STEP1 time	1-9990,9999	0.1-999 SEC, 9999 = continuous irradiation
§		§	§	§
05292		Type 2 LED4 STEP10 intensity	0-100	0-100%
05293		Type 2 LED4 STEP10 time	1-9990,9999	0.1-999 SEC, 9999 = continuous irradiation
05304		Type 3 LED1 STEP1 power	0-100	0-100%
05305		Type 3 LED1 STEP1 time	1-9990,9999	0.1-999 SEC, 9999 = continuous irradiation.
§		§	§	§
05322		Type 3 LED1 STEP10 power	0-100	0-100%
05323		Type 3 LED1 STEP10 time	1-9990,9999	0.1-999 SEC, 9999 = continuous irradiation
05324		Type 3 LED2 STEP1 power	0-100	0-100%
05325		Type 3 LED2 STEP1 time	1-9990,9999	0.1-999 SEC, 9999 = continuous irradiation
§		§	§	§
05342		Type 3 LED2 STEP10 power	0-100	0-100%
05343		Type 3 LED2 STEP10 time	1-9990,9999	0.1-999 SEC, 9999 = continuous irradiation

# External control

Address	ON bits	Name	Data	Description
05344		Type 3 LED3 STEP1 intensity	0-100	0-100%
05345		Type 3 LED3 STEP1 time	1-9990,9999	0.1-999 SEC, 9999 = continuous irradiation
		§	§	§
05362		Type 3 LED3 STEP10 intensity	0-100	0-100%
05363		Type 3 LED3 STEP10 time	1-9990,9999	0.1-999 SEC, 9999 = continuous irradiation
05364		Type 3 LED4 STEP1 intensity	0-100	0-100%
05365		Type 3 LED4 STEP1 time	1-9990,9999	0.1-999 SEC, 9999 = continuous irradiation
		§	§	§
05382		Type 3 LED4 STEP10 intensity	0-100	0-100%
05383		Type 3 LED4 STEP10 time	1-9990,9999	0.1-999 SEC, 9999 = continuous irradiation
05394		Type 4 LED1 STEP1 intensity	0-100	0-100%
05395		Type 4 LED1 STEP1 time	1-9990,9999	0.1-999 SEC, 9999 = continuous irradiation
		§	§	§
05412		Type 4 LED1 STEP10 intensity	0-100	0-100%
05413		Type 4 LED1 STEP10 time	1-9990,9999	0.1-999 SEC, 9999 = continuous irradiation
05414		Type 4 LED2 STEP1 intensity	0-100	0-100%
05415		Type 4 LED2 STEP1 time	1-9990,9999	0.1-999 SEC, 9999 = continuous irradiation
		§	§	§
05432		Type 4 LED2 STEP10 intensity	0-100	0-100%
05433		Type 4 LED2 STEP10 time	1-9990,9999	0.1-999 SEC, 9999 = continuous irradiation
05434		Type 4 LED3 STEP1 intensity	0-100	0-100%
05435		Type 4 LED3 STEP1 time	1-9990,9999	0.1-999 SEC, 9999 = continuous irradiation
		§	§	§
05452		Type 4 LED3 STEP10 intensity	0-100	0-100%
05453		Type 4 LED3 STEP10 time	1-9990,9999	0.1-999 SEC, 9999 = continuous irradiation
05454		Type 4 LED4 STEP1 intensity	0-100	0-100%
05455		Type 4 LED4 STEP1 time	1-9990,9999	0.1-999 SEC, 9999 = continuous irradiation
		§	§	§
05472		Type 4 LED4 STEP10 intensity	0-100	0-100%
05473		Type 4 LED4 STEP10 time	1-9990,9999	0.1-999 SEC, 9999 = continuous irradiation
05484		Type 5 LED1 STEP1 intensity	0-100	0-100%
05485		Type 5 LED1 STEP1 time	1-9990,9999	0.1-999 SEC, 9999 = continuous irradiation
		§	§	§
05502		Type 5 LED1 STEP10 intensity	0-100	0-100%
05503		Type 5 LED1 STEP10 time	1-9990,9999	0.1-999 SEC, 9999 is continuous irradiation.
05504		Type 5 LED2 STEP1 intensity	0-100	0-100%
05505		Type 5 LED2 STEP1 time	1-9990,9999	0.1-999 SEC, 9999 = continuous irradiation
		§	§	§
05522		Type 5 LED2 STEP10 intensity	0-100	0-100%
05523		Type 5 LED2 STEP10 time	1-9990,9999	0.1-999 SEC, 9999 = continuous irradiation
05524		Type 5 LED3 STEP1 intensity	0-100	0-100%
05525		Type 5 LED3 STEP1 time	1-9990,9999	0.1-999 SEC, 9999 = continuous irradiation
		§	§	§
05542		Type 5 LED3 STEP10 intensity	0-100	0-100%
05543		Type 5 LED3 STEP10 time	1-9990,9999	0.1-999 SEC, 9999 = continuous irradiation
05544		Type 5 LED4 STEP1 intensity	0-100	0-100%
05545		Type 5 LED4 STEP1 time	1-9990,9999	0.1-999 SEC, 9999 = continuous irradiation
		§	§	§
05562		Type 5 LED4 STEP10 intensity	0-100	0-100%
05563		Type 5 LED4 STEP10 time	1-9990,9999	0.1-999 SEC, 9999 = continuous irradiation
05574		Type 6 LED1 STEP1 intensity	0-100	0-100%
05575		Type 6 LED1 STEP1 time	1-9990,9999	0.1-999 SEC, 9999 = continuous irradiation
		§	§	§
05592		Type 6 LED1 STEP10 intensity	0-100	0-100%
05593		Type 6 LED1 STEP10 time	1-9990,9999	0.1-999 SEC, 9999 = continuous irradiation
05594		Type 6 LED2 STEP1 intensity	0-100	0-100%
05595		Type 6 LED2 STEP1 time	1-9990,9999	0.1-999 SEC, 9999 = continuous irradiation
		§	§	§
05612		Type 6 LED2 STEP10 intensity	0-100	0-100%
05613		Type 6 LED2 STEP10 time	1-9990,9999	0.1-999 SEC, 9999 is continuous irradiation.
05614		Type 6 LED3 STEP1 intensity	0-100	0-100%
05615		Type 6 LED3 STEP1 time	1-9990,9999	0.1-999 SEC, 9999 = continuous irradiation
		§	§	§
05632		Type 6 LED3 STEP10 intensity	0-100	0-100%
05633		Type 6 LED3 STEP10 time	1-9990,9999	0.1-999 SEC, 9999 = continuous irradiation
05634		Type 6 LED4 STEP1 intensity	0-100	0-100%
05635		Type 6 LED4 STEP1 time	1-9990,9999	0.1-999 SEC, 9999 = continuous irradiation
		§	§	§
05652		Type 6 LED4 STEP10 intensity	0-100	0-100%
05653		Type 6 LED4 STEP10 time	1-9990,9999	0.1-999 SEC, 9999 = continuous irradiation
05664		Type 7 LED1 STEP1 intensity	0-100	0-100%
05665		Type 7 LED1 STEP1 time	1-9990,9999	0.1-999 SEC, 9999 = continuous irradiation
		§	§	§
05682		Type 7 LED1 STEP10 intensity	0-100	0-100%
05683		Type 7 LED1 STEP10 time	1-9990,9999	0.1-999 SEC, 9999 = continuous irradiation
05684		Type 7 LED2 STEP1 intensity	0-100	0-100%
05685		Type 7 LED2 STEP1 time	1-9990,9999	0.1-999 SEC, 9999 = continuous irradiation
		§	§	§
05702		Type 7 LED2 STEP10 intensity	0-100	0-100%
05703		Type 7 LED2 STEP10 time	1-9990,9999	0.1-999 SEC, 9999 = continuous irradiation
05704		Type 7 LED3 STEP1 intensity	0-100	0-100%
05705		Type 7 LED3 STEP1 time	1-9990,9999	0.1-999 SEC, 9999 = continuous irradiation
		§	§	§
05722		Type 7 LED3 STEP10 intensity	0-100	0-100%
05723		Type 7 LED3 STEP10 time	1-9990,9999	0.1-999 SEC, 9999 is continuous irradiation.
05724		Type 7 LED4 STEP1 intensity	0-100	0-100%
05725		Type 7 LED4 STEP1 time	1-9990,9999	0.1-999 SEC, 9999 = continuous irradiation
		§	§	§
05742		Type 7 LED4 STEP10 intensity	0-100	0-100%
05743		Type 7 LED4 STEP10 time	1-9990,9999	0.1-999 SEC, 9999 = continuous irradiation

# External control

Address	ON bits	Name	Data	Description
06500		READY/BUSY switching	0,1	External output READY/BUSY switching (0: READY/1: BUSY)
06501	0	Buzzer (when error occurs)	-	For each bit, "1" = Buzzer OFF
	1	Buzzer (when SET switch is ON)	-	
	2	Buzzer (when EMISSION switch is ON)	-	
	3	Buzzer (when MODE switch is ON)	-	
	4	Buzzer (when CH1-4 switch a turned ON)	-	
	5	Buzzer (UV CHK: switch ON, at time of external input or communication)	-	
	6	Buzzer (when communication data is changed or when writing to memory)	-	
	7	Buzzer (start/stop: at time of external input or communication)	-	
	8	Buzzer (when ▲▼ switch is ON)	-	
	9	Buzzer (lock function is set)	-	
	10	Buzzer (when calibration is completed)	-	
	11	Buzzer (when power is turned ON)	-	
06502		Temperature display setting	0,1	0: = °C display, 1 = °F display
06505		Each display of the controller	0-3	For all displays, (0: %, SEC, 1: TEMP, 2: ×100hrs, 3: W/cm2)
06510		LED1 replacement time setting (higher byte)	0-999000	CH1 current replacement time (units: 0.1 hr, 1= 0.1 hr)
06511		LED1 replacement time setting (lower byte)		
06512		LED2 replacement time setting (higher byte)	0-999000	CH2 current replacement time
06513		LED2 replacement time setting (lower byte)		
06514		LED3 replacement time setting (higher byte)	0-999000	CH3 current replacement time
06515		LED3 replacement time setting (lower byte)		
06516		LED4 replacement time setting (higher byte)	0-999000	CH4 current replacement time
06517		LED4 replacement time setting (lower byte)		
06526	0	READY1	-	For each bit, "1" = current signal output.
	1	READY2	-	
	2	READY3	-	
	3	READY4	-	
	4	BUSY1	-	
	5	BUSY2	-	
	6	BUSY3	-	
	7	BUSY4	-	
06530		UV measurement value during STEP1 calibration	0-9990	Each STEP for types 1 to 7 UV measurement value during calibration (0-9990 (×0.01) W/cm2) (The UV measurement value is retained when calibration is completed.)
06531		UV measurement value during STEP2 calibration	0-9990	
06532		UV measurement value during STEP3 calibration	0-9990	
06533		UV measurement value during STEP4 calibration	0-9990	
06534		UV measurement value during STEP5 calibration	0-9990	
06535		UV measurement value during STEP6 calibration	0-9990	
06536		UV measurement value during STEP7 calibration	0-9990	
06537		UV measurement value during STEP8 calibration	0-9990	
06538		UV measurement value during STEP9 calibration	0-9990	
06539		UV measurement value during STEP10 calibration	0-9990	
06540		UV intensity during STEP1 calibration	0-100	Each STEP for types1 to 7 UV modulation 1-100% --> Reset when starting calibration (The UV modulation value is retained when calibration is completed.)
06541		UV intensity during STEP2 calibration	0-100	
06542		UV intensity during STEP3 calibration	0-100	
06543		UV intensity during STEP4 calibration	0-100	
06544		UV intensity during STEP5 calibration	0-100	
06545		UV intensity during STEP6 calibration	0-100	
06546		UV intensity during STEP7 calibration	0-100	
06547		UV intensity during STEP8 calibration	0-100	
06548		UV intensity during STEP9 calibration	0-100	
06549		UV intensity during STEP10 calibration	0-100	
06551		LED1 calibration error STEP1-10	-	TYPE1-7 [E60-69] For each bit, "1" = error.
06552		LED2 calibration error STEP1-10	-	
06553		LED3 calibration error STEP1-10	-	
06554		LED4 calibration error STEP1-10	-	

# External control

■ Address for writing (“1 address = 16bit”)

□ ...New settings take effect when the address of the data setting is executed.

(The settings are saved to memory when power is turned OFF.)

To save new settings, rewrite to memory and then execute the address.

Note: Memory can be rewritten up to one million times. If you rewrite to memory frequently, you may only be able to execute data settings, so write only the final data to memory.

Data, operation, and memory inputs and commands are accepted at any time, but during operation they will be reflected only after the controller returns to standby mode. Note, however, that changes to replacement time and cumulative irradiation time settings are not accepted during irradiation.

It is also possible to read the WRITE addresses.

Address	ON bits	Name	Data	Description	Timing of reflection to controller operation
07002		UV-CHK measurement	0,1	UV-CHK 1: measurement mode	Referenced even during measurement and calibration.
07004		UV-CHK calibration	0,1	UV-CHK 1: calibration mode	When operation is started from this address, operation will stop when value is switched to "0." (Addresses 07002 and 07004 cannot be "1" at the same time.)
07005		RESET	0,1	1: Error reset and return to initial screen	
07018		All start (EMISSION)	0,1	1: Start irradiation on selected CH	
07021		UV-CHK TYPED intensity input	1-4990	Set TYPED calibration (setting value $\times 0.01$ ) 0.01-49.9 W/cm <sup>2</sup>	Writing to memory can be done at any time. Changes are reflected in operation at the start of calibration.
07023		Switch UV measurement range	0-2	1: Switch to LOW range, 2: Switch to HIGH range ("0" does nothing.)	Reflected during measurement, but cannot be accepted during calibration
07024					
07025		Interlock ON/OFF order	0,1	"1" = ON/OFF switching (Locks SET switch, so that no settings can be changed)	Reflected to locking operation only in standby mode (for operation mode and UV-CHK mode). Communication settings can be changed even when lock is activated.
07044		Switch TYPE (0-7)	0-8	"0" for no TYPE switching, "1" for TYPE0, "8" for TYPE7	Switches from one TYPE to another (only when 10 is not set). Reflected in actual operation only in standby mode.
07100		Selection LED1	0,1	0: No selection, 1: CH1 selected	
07101		Selection LED2	0,1	0: No selection, 1: CH2 selected	New settings take effect when the address of the data setting is executed. (The settings are saved to memory when power is turned OFF.)
07102		Selection LED3	0,1	0: No selection, 1: CH3 selected	To save new settings, rewrite to memory and then execute the address. (Note: Memory can be rewritten up to one million times.)
07103		Selection LED4	0,1	0: No selection, 1: CH4 selected	
07104		TYPED LED1 intensity	0-100	Set CH1 irradiation intensity (0-100%)	
07105		TYPED LED1 time	0-9990,9999	Set CH1 irradiation time (0-9990s, 9999 = continuous) $\times 0.1$	
07106		TYPED LED2 intensity	0-100	Set CH2 irradiation intensity (0-100%)	New settings take effect when the address of the data setting is executed. (The settings are saved to memory when power is turned OFF.)
07107		TYPED LED2 time	0-9990,9999	Set CH2 irradiation time (0-9990s, 9999 = continuous) $\times 0.1$	To save new settings, rewrite to memory and then execute the address. (Note: Memory can be rewritten up to one million times.)
07108		TYPED LED3 intensity	0-100	Set CH3 irradiation intensity (0-100%)	
07109		TYPED LED3 time	0-9990,9999	Set CH3 irradiation time (0-9990s, 9999 = continuous) $\times 0.1$	
07110		TYPED LED4 intensity	0-100	Set CH4 irradiation intensity (0-100%)	
07111		TYPED LED4 time	0-9990,9999	Set CH4 irradiation time (0-9990s, 9999 = continuous) $\times 0.1$	
07124		Type 1 LED1 STEP1 intensity	0-100	Set CH1 STEP1 irradiation intensity (0-100%)	
07125		Type 1 LED1 STEP1 time	0-9990,9999	Set CH1 STEP1 irradiation time (0-9990s, 9999 = continuous) $\times 0.1$	
§		§	§	§	
07142		Type 1 LED1 STEP10 intensity	0-100	Set CH1 STEP10 irradiation intensity (0-100%)	
07143		Type 1 LED1 STEP10 time	0-9990,9999	Set CH1 STEP10 irradiation time (0-9990s, 9999 = continuous) $\times 0.1$	
07144		Type 1 LED2 STEP1 intensity	0-100	Set CH2 STEP1 irradiation intensity (0-100%)	
07145		Type 1 LED2 STEP1 time	0-9990,9999	Set CH2 STEP1 irradiation time (0-9990s, 9999 = continuous) $\times 0.1$	
§		§	§	§	
07162		Type 1 LED2 STEP10 intensity	0-100	Set CH2 STEP10 irradiation intensity (0-100%)	New settings take effect when the address of the data setting is executed. (The settings are saved to memory when power is turned OFF.)
07163		Type 1 LED2 STEP10 time	0-9990,9999	Set CH2 STEP10 irradiation time (0-9990s, 9999 = continuous) $\times 0.1$	To save new settings, rewrite to memory and then execute the address. (Note: Memory can be rewritten up to one million times.)
07164		Type 1 LED3 STEP1 intensity	0-100	Set CH3 STEP1 irradiation intensity (0-100%)	
07165		Type 1 LED3 STEP1 time	0-9990,9999	Set CH3 STEP1 irradiation time (0-9990s, 9999 = continuous) $\times 0.1$	
§		§	§	§	
07182		Type 1 LED3 STEP10 intensity	0-100	Set CH3 STEP10 step irradiation intensity (0-100%)	
07183		Type 1 LED3 STEP10 time	0-9990,9999	Set CH3 STEP10 irradiation time (0-9990s, 9999 = continuous) $\times 0.1$	
07184		Type 1 LED4 STEP1 intensity	0-100	Set CH4 STEP1 irradiation intensity (0-100%)	
07185		Type 1 LED4 STEP1 time	0-9990,9999	Set CH4 STEP1 irradiation time (0-9990s, 9999 = continuous) $\times 0.1$	
§		§	§	§	
07202		Type 1 LED4 STEP10 intensity	0-100	Set CH4 STEP10 irradiation intensity (0-100%)	
07203		Type 1 LED4 STEP10 time	0-9990,9999	Set CH4 STEP10 irradiation time (0-9990s, 9999 = continuous) $\times 0.1$	
07214		Type 2 LED1 STEP1 intensity	0-100	Set CH1 STEP1 irradiation intensity (0-100%)	
07215		Type 2 LED1 STEP1 time	0-9990,9999	Set CH1 STEP1 irradiation time (0-9990s, 9999 = continuous) $\times 0.1$	
§		§	§	§	
07232		Type 2 LED1 STEP10 intensity	0-100	Set CH1 STEP10 irradiation intensity (0-100%)	
07233		Type 2 LED1 STEP10 time	0-9990,9999	Set CH1 STEP10 irradiation time (0-9990s, 9999 = continuous) $\times 0.1$	
07234		Type 2 LED2 STEP1 intensity	0-100	Set CH2 STEP1 irradiation intensity (0-100%)	
07235		Type 2 LED2 STEP1 time	0-9990,9999	Set CH2 STEP1 irradiation time (0-9990s, 9999 = continuous) $\times 0.1$	
§		§	§	§	
07252		Type 2 LED2 STEP10 intensity	0-100	Set CH2 STEP10 irradiation intensity (0-100%)	New settings take effect when the address of the data setting is executed. (The settings are saved to memory when power is turned OFF.)
07253		Type 2 LED2 STEP10 time	0-9990,9999	Set CH2 STEP10 irradiation time (0-9990s, 9999 = continuous) $\times 0.1$	To save new settings, rewrite to memory and then execute the address. (Note: Memory can be rewritten up to one million times.)
07254		Type 2 LED3 STEP1 intensity	0-100	Set CH3 STEP1 irradiation intensity (0-100%)	
07255		Type 2 LED3 STEP1 time	0-9990,9999	Set CH3 STEP1 irradiation time (0-9990s, 9999 = continuous) $\times 0.1$	
§		§	§	§	
07272		Type 2 LED3 STEP10 intensity	0-100	Set CH3 STEP10 irradiation intensity (0-100%)	
07273		Type 2 LED3 STEP10 time	0-9990,9999	Set CH3 STEP10 irradiation time (0-9990s, 9999 = continuous) $\times 0.1$	
07274		Type 2 LED4 STEP1 intensity	0-100	Set CH4 STEP1 irradiation intensity (0-100%)	
07275		Type 2 LED4 STEP1 time	0-9990,9999	Set CH4 STEP1 irradiation time (0-9990s, 9999 = continuous) $\times 0.1$	
§		§	§	§	
07292		Type 2 LED4 STEP10 intensity	0-100	Set CH4 STEP10 irradiation intensity (0-100%)	
07293		Type 2 LED4 STEP10 time	0-9990,9999	Set CH4 STEP10 irradiation time (0-9990s, 9999 = continuous) $\times 0.1$	



# External control

Address	ON bits	Name	Data	Description	Timing of reflection to controller operation	
07664		Type 7 LED1 STEP1 intensity	0-100	Set CH1 STEP1 irradiation intensity (0-100%)	New settings take effect when the address of the data setting is executed. (The settings are saved to memory when power is turned OFF.) To save new settings, rewrite to memory and then execute the address. (Note: Memory can be rewritten up to one million times.)	
07665		Type 7 LED1 STEP1 time	0-9990,9999	Set CH1 STEP1 irradiation time (0-9990s, 9999 = continuous) ×0.1		
07682		Type 7 LED1 STEP10 intensity	0-100	Set CH1 STEP10 irradiation intensity (0-100%)		
07683		Type 7 LED1 STEP10 time	0-9990,9999	Set CH1 STEP10 irradiation time (0-9990s, 9999 = continuous) ×0.1		
07684		Type 7 LED2 STEP1 intensity	0-100	Set CH2 STEP1 irradiation intensity (0-100%)		
07685		Type 7 LED2 STEP1 time	0-9990,9999	Set CH2 STEP1 irradiation time (0-9990s, 9999 = continuous) ×0.1		
07702		Type 7 LED2 STEP10 intensity	0-100	Set CH2 STEP10 irradiation intensity (0-100%)		
07703		Type 7 LED2 STEP10 time	0-9990,9999	Set CH2 STEP10 irradiation time (0-9990s, 9999 = continuous) ×0.1		
07704		Type 7 LED3 STEP1 intensity	0-100	Set CH3 STEP1 irradiation intensity (0-100%)		
07705		Type 7 LED3 STEP1 time	0-9990,9999	Set CH3 STEP1 irradiation time (0-9990s, 9999 = continuous) ×0.1		
07722		Type 7 LED3 STEP10 intensity	0-100	Set CH3 STEP10 irradiation intensity (0-100%)		
07723		Type 7 LED3 STEP10 time	0-9990,9999	Set CH3 STEP10 irradiation time (0-9990s, 9999 = continuous) ×0.1		
07724		Type 7 LED4 STEP1 intensity	0-100	Set CH4 STEP1 irradiation intensity (0-100%)		
07725		Type 7 LED4 STEP1 time	0-9990,9999	Set CH4 STEP1 irradiation time (0-9990s, 9999 = continuous) ×0.1		
07742		Type 7 LED4 STEP10 intensity	0-100	Set CH4 STEP10 irradiation intensity (0-100%)		
07743		Type 7 LED4 STEP10 time	0-9990,9999	Set CH4 STEP10 irradiation time (0-9990s, 9999 = continuous) ×0.1		
08500		LED1 start (EMISSION)	0,1	1: CH1 start signal ON, 0: CH1 start signal OFF		Starts irradiation for each CH. (Start ON is not accepted during calibration.) Referenced even during measurement and calibration. When operation is started from this address, operation will stop when value is switched to "0."
08501		LED2 start (EMISSION)	0,1	1: CH2 start signal ON, 0: CH2 start signal OFF		
08502		LED3 start (EMISSION)	0,1	1: CH3 start signal ON, 0: CH3 start signal OFF		
08503		LED4 start (EMISSION)	0,1	1: CH4 start signal ON, 0: CH4 start signal OFF		
08510		Stop irradiation	0,1	1: Stop irradiation (stops irradiation of selected CH)	Reflected in operation only during irradiation (except during UV measurement and calibration). (Irradiation will stop.)	
08600		TYPE switching data memory	0,1	"1" when writing TYPE switch to memory	TYPE switch is written to memory. Changes back to "0" after completion of WRITE.	
08601		TYPE switching setting	0,1	1: Changes TYPE switching data	TYPE switching data is changed. Changes back to "0" after completion of change.	
08619	0	TYPE0 TYPE data setting	-		Only the irradiation intensity and time data of the changed addresses are changed. Settings are saved to memory when power is turned OFF. Changes back to "0" after completion of change.	
	1	TYPE1 TYPE data setting	-			
	2	TYPE2 TYPE data setting	-			
	3	TYPE3 TYPE data setting	-			
	4	TYPE4 TYPE data setting	-	For each bit, "1" changes the setting.		
	5	TYPE5 TYPE data setting	-			
	6	TYPE6 TYPE data setting	-			
	7	TYPE7 TYPE data setting	-			
08620	0	TYPE0 TYPE data memory	-		Only the irradiation intensity and time data of the changed addresses are changed. (Note: Memory can be rewritten up to one million times.) Changes back to "0" after completion of change. Writing to memory can be done at any time. Changes are reflected in actual operation only in standby mode.	
	1	TYPE1 TYPE data memory	-			
	2	TYPE2 TYPE data memory	-			
	3	TYPE3 TYPE data memory	-	For each bit, "1" writes to memory.		
	4	TYPE4 TYPE data memory	-			
	5	TYPE5 TYPE data memory	-			
	6	TYPE6 TYPE data memory	-			
	7	TYPE7 TYPE data memory	-			
08700		READY/BUSY switching	0,1	0: READY, 1: BUSY (switches READY/BUSY external output)	Can be reflected in operation and saved to memory at anytime.	
08702		%SEC, TEMP, × 100hrs display	0-3	1: displays 1/SEC, 2: displays TEMP, 3: displays ×100hrs ("0" does nothing.)	Reflected in operation only in irradiation mode (in standby mode during irradiation). Is ignored at other times.	
08703		Temperature display switching	0,1	0: °C, 1: °F (switches units of head temperature display between Celsius/Fahrenheit)	Can be reflected in operation and saved to memory at any time.	
08705		CH1 UV measurement intensity input	0-100	UV intensity control mode, UV measurement intensity input "000-100%"	Reflected in operation only during UV measurement (during irradiation). Is ignored at other times.	
08706		CH2 UV measurement intensity input	0-100	UV intensity control mode, UV measurement intensity input "000-100%"		
08707		CH3 UV measurement intensity input	0-100	UV intensity control mode, UV measurement intensity input "000-100%"		
08708		CH4 UV measurement intensity input	0-100	UV intensity control mode, UV measurement intensity input "000-100%"		
08710		LED1 total irradiation time (higher byte)		Set CH1 total irradiation time (×100hrs) (units: 0.1 hr, 1÷0.1 hr)	Can be reflected in operation and saved to memory at any time except during irradiation. Is ignored during irradiation time. (It will not be automatically reflected and saved to memory after irradiation stops.)	
08711		LED1 total irradiation time (lower byte)	0-999000			
08712		LED2 total irradiation time (higher byte)		Set CH2 total irradiation time (×100hrs) (units: 0.1 hr, 1÷0.1 hr)		
08713		LED2 total irradiation time (lower byte)	0-999000			
08714		LED3 total irradiation time (higher byte)		Set CH3 total irradiation time (×100hrs) (units: 0.1 hr, 1÷0.1 hr)		
08715		LED3 total irradiation time (lower byte)	0-999000			
08716		LED4 total irradiation time (higher byte)		Set CH4 total irradiation time (×100hrs) (units: 0.1 hr, 1÷0.1 hr)		
08717		LED4 total irradiation time (lower byte)	0-999000			
08724	0	Buzzer (when an error occurs)	-			When set to OFF the buzzer sounds when an error occurs.
	1	Buzzer (when SET switch is ON)	-			
	2	Buzzer (when EMISSION switch is ON)	-			
	3	Buzzer (when MODE switch is ON)	-			
	4	Buzzer (when CH1-4 switch is ON)	-			
	5	Buzzer (UV CHK switch ON, at time of external input or communication)	-			
	6	Buzzer (when communication data is changed or when writing to memory)	-			
	7	Buzzer (Start/stop, at time of external input or communication)	-			
	9	Buzzer (when ▲ switch is ON)	-			
	10	Buzzer (when calibration is completed)	-			
	11	Buzzer (when power is turned ON)	-			

# External control

Address	ON bits	Name	Data	Description	Timing of reflection to controller operation
08726		UV-CHK switch	0,1	1: UV-CHK switch ON (shift to UV intensity control mode)	Reflected in operation in standby mode during irradiation, or in UV-CHK mode. Is ignored at other times.
08728		UV-CHK STEP1 intensity input	0-4990	Set calibration settings for each STEP of TYPE1-7 Setting values <math>\times 0.01</math> (0.00-49.9 W/cm <sup>2</sup> )	Writing to memory can be done at any time. Reflected in operation at the start of calibration.
08729		UV-CHK STEP2 intensity input	0-4990		
08730		UV-CHK STEP3 intensity input	0-4990		
08731		UV-CHK STEP4 intensity input	0-4990		
08732		UV-CHK STEP5 intensity input	0-4990		
08733		UV-CHK STEP6 intensity input	0-4990		
08734		UV-CHK STEP7 intensity input	0-4990		
08735		UV-CHK STEP8 intensity input	0-4990		
08736		UV-CHK STEP9 intensity input	0-4990		
08737		UV-CHK STEP10 power input	0-4990		
08738	0	CH1 total time setting	-	For each bit, "1" is to set data.	Can be reflected in operation and saved to memory at any time except during irradiation. Is ignored during irradiation time. (It will not be automatically reflected and saved to memory after irradiation stops.)
	1	CH2 total time setting	-		
	2	CH3 total time setting	-		
	3	CH4 total time setting	-		
	4	CH selection setting	-		
	5	Temperature display switch setting	-		
	6	Buzzer ON/OFF setting	-		
	7	Interlock ON/OFF setting	-		
	8	READY/BUSY switch setting	-		
	9	CH1 replacement time setting	-		
	10	CH2 replacement time setting	-		
	11	CH3 replacement time setting	-		
	12	CH4 replacement time setting	-		
	13	UV intensity setting	-		
	14	UV intensity setting	-		
08739	0	CH1 total time memory	-	For each bit, "1" is to write data to memory.	Can be reflected in operation and saved to memory at any time except during irradiation. Is ignored during irradiation time. (It will not be automatically reflected and saved to memory after irradiation stops.)
	1	CH2 total time memory	-		
	2	CH3 total time memory	-		
	3	CH4 total time memory	-		
	4	CH selection memory	-		
	5	Temperature display switch memory	-		
	6	Buzzer ON/OFF memory	-		
	7	Interlock ON/OFF memory	-		
	8	READY/BUSY switch memory	-		
	9	CH1 replacement time memory	-		
	10	CH2 replacement time memory	-		
	11	CH3 replacement time memory	-		
	12	CH4 replacement time memory	-		
	13	UV intensity setting memory	-		
	14	UV intensity setting memory	-		
08740		LED1 replacement time setting (higher byte)	0-999000	Set CH1 replacement time setting (units: 0.1 hr, 1<math>\times</math>0.1 hr)	Can be reflected in operation and saved to memory at any time except during irradiation. Is ignored during irradiation time. (It will not be automatically reflected and saved to memory after irradiation stops.)
08741		LED1 replacement time setting (lower byte)			
08742		LED2 replacement time setting (higher byte)	0-999000	Set CH2 replacement time setting (units: 0.1 hr, 1<math>\times</math>0.1 hr)	
08743		LED2 replacement time setting (lower byte)			
08744		LED3 replacement time setting (higher byte)	0-999000	Set CH3 replacement time setting (units: 0.1 hr, 1<math>\times</math>0.1 hr)	
08745		LED3 replacement time setting (lower byte)			
08746		LED4 replacement time setting (higher byte)	0-999000	Set CH4 replacement time setting (units: 0.1 hr, 1<math>\times</math>0.1 hr)	
08747		LED4 replacement time setting (lower byte)			

# External control

## WRITE procedure

• Communication data is accepted at each address, and the accepted data will be confirmed by the execution of the data setting address and data memory address.

–Data confirmed by the setting address will be written to memory when the controller is powered OFF.

Data confirmed by the memory address will be written to memory and be retained even after the controller is powered OFF.

- Note: 1. Memory can be rewritten up to one million times. If you rewrite to memory frequently, you may only be able to execute data settings, so write only the final data to memory.  
 2. Write data in hexadecimal.

	Procedure	Address	Bits	Data	Comments
switch TYPE	①	07044		Sets "1" for TYPED, sets "0" for TYPE7	Switches TYPE (only when I/O is not set).
(in case of data setting)	②	08601		"1" sets data.	Confirms the setting (setting is restored to memory when power is turned OFF)
(in case of data memory)	③	08600		"1" writes data to memory.	Confirms the setting and writes it to memory (Use communication to revert to TYPED)
CH selection	①	07100~07103		Select LED1-4. "1" selects.	Sets CH selection (CH1-4)
(in case of data setting)	②	08738	4	"1" sets data for each bit.	Confirms the setting (setting is restored to memory when power is turned OFF)
(in case of data memory)	③	08739	4	"1" writes data to memory for each bit.	Confirms the setting and writes it to memory
TYPED irradiation intensity irradiation time setting	①	07104~07111		TYPED LED1-4 intensity, time (STEP1-10)	Sets CH1-4 irradiation intensity and irradiation time
(in case of data setting)	②	08619	0	"1" sets data for each bit.	Confirms the setting (setting is restored to memory when power is turned OFF)
(in case of data memory)	③	08620	0	"1" writes data to memory for each bit.	Confirms the setting and writes it to memory
TYPE1 irradiation intensity irradiation time setting	①	07124~07203		TYPE1 LED1-4 intensity, time (STEP1-10)	Sets CH1-4 irradiation intensity and irradiation time
(in case of data setting)	②	08619	1	"1" sets data for each bit.	Confirms the setting (setting is restored to memory when power is turned OFF)
(in case of data memory)	③	08620	1	"1" writes data to memory for each bit.	Confirms the setting and writes it to memory
TYPE2 irradiation intensity irradiation time setting	①	07214~07293		TYPE2 LED1-4 intensity, time (STEP1-10)	Sets CH1-4 irradiation intensity and irradiation time
(in case of data setting)	②	08619	2	"1" sets data for each bit.	Confirms the setting (setting is restored to memory when power is turned OFF)
(in case of data memory)	③	08620	2	"1" writes data to memory for each bit.	Confirms the setting and writes it to memory
TYPE3 irradiation intensity irradiation time setting	①	07304~07383		TYPE3 LED1-4 intensity, time (STEP1-10)	Sets CH1-4 irradiation intensity and irradiation time
(in case of data setting)	②	08619	3	"1" sets data for each bit.	Confirms the setting (setting is restored to memory when power is turned OFF)
(in case of data memory)	③	08620	3	"1" writes data to memory for each bit.	Confirms the setting and writes it to memory
TYPE4 irradiation intensity irradiation time setting	①	07394~07473		TYPE4 LED1-4 intensity, time (STEP1-10)	Sets CH1-4 irradiation intensity and irradiation time
(in case of data setting)	②	08619	4	"1" sets data for each bit.	Confirms the setting (setting is restored to memory when power is turned OFF)
(in case of data memory)	③	08620	4	"1" writes data to memory for each bit.	Confirms the setting and writes it to memory
TYPE5 irradiation intensity irradiation time setting	①	07484~07563		TYPE5 LED1-4 intensity, time (STEP1-10)	Sets CH1-4 irradiation intensity and irradiation time
(in case of data setting)	②	08619	5	"1" sets data for each bit.	Confirms the setting (setting is restored to memory when power is turned OFF)
(in case of data memory)	③	08620	5	"1" writes data to memory for each bit.	Confirms the setting and writes it to memory
TYPE6 irradiation intensity irradiation time setting	①	07574~07653		TYPE6 LED1-4 intensity, time (STEP1-10)	Sets CH1-4 irradiation intensity and irradiation time
(in case of data setting)	②	08619	6	"1" sets data for each bit.	Confirms the setting (setting is restored to memory when power is turned OFF)
(in case of data memory)	③	08620	6	"1" writes data to memory for each bit.	Confirms the setting and writes it to memory
TYPE7 irradiation intensity irradiation time setting	①	07664~07743		TYPE7 LED1-4 intensity, time (STEP1-10)	Sets CH1-4 irradiation intensity and irradiation time
(in case of data setting)	②	08619	7	"1" sets data for each bit.	Confirms the setting (setting is restored to memory when power is turned OFF)
(in case of data memory)	③	08620	7	"1" writes data to memory for each bit.	Confirms the setting and writes it to memory
Batch irradiation	①	07018		Starts all irradiation (BMISSION), starts on switch from "0" to "1"	Starts irradiation on selected CH
Individual irradiation	①	08500~08503		Starts LED1-4 (BMISSION), starts on switch from "0" to "1"	Starts irradiation on each CH
Irradiation stop	①	08510		Stops irradiation, stops on switch from "0" to "1"	Stops irradiation on selected CH
UV intensity measurement	①	08728		"1" turns UV CHK switch ON.	Switches to UV intensity control mode
No particular writing order	②	07002		"1" is UV CHK measurement mode.	Sets UV intensity measurement mode
(Start measurement)	③	08705~08708		CH1-4 UV measurement intensity input "0"~"100"	Sets irradiation intensity when measuring CH1-4 UV intensity
	④	07018		"1" starts all (BMISSION).	Starts irradiation and UV measurement on selected CH
	⑤	08500~08503		"1" start each of LED1-4 (BMISSION).	Starts irradiation and UV measurement on each CH
Calibration (TYPED)	①	08728		"1" turns UV CHK switch ON.	Switches to UV intensity control mode
No particular writing order	②	07004		"1" is UV CHK calibration mode.	Switches to calibration mode
(in case of data setting)	③	07021		UV CHK TYPED intensity input "0"~"100"	Sets calibration setting for TYPED.
(in case of data memory)	④	08738	13	"1" sets data for each bit.	Confirms setting for TYPED (Settings are restored to memory when power is turned OFF.)
(Start calibration)	⑤	08739	13	"1" writes data to memory for each bit.	Confirms setting for TYPED and writes it to memory
	⑥	07018		Starts all (BMISSION).	Starts irradiation on selected CH
	⑦	08500~08503		Starts LED1-4 (BMISSION).	Starts irradiation on each CH
Calibration (TYPE1-7)	①	08728		"1" turns UV CHK switch ON.	Switches to UV intensity control mode
No particular writing order	②	07004		"1" is UV CHK calibration mode.	Sets calibration mode
(in case of data setting)	③	08728~08737		UV CHK STEP1-10 intensity input "0"~"100"	Sets calibration setting for each STEP of TYPE1-7
(in case of data memory)	④	08738	14	"1" sets data for each bit.	Confirms setting of TYPE1-7 (Settings are restored to memory when power is turned OFF.)
(Start calibration)	⑤	08739	14	"1" writes data to memory for each bit.	Confirms setting of TYPE1-7 and writes it to memory
	⑥	07018		Starts all (BMISSION).	Starts irradiation on selected CH
	⑦	08500~08503		Start LED1-4 (BMISSION)	Starts irradiation on each CH
READY/BUSY switching	①	08700		"0" when READY, "1" when BUSY	Switches READY/BUSY status of external output
(in case of data setting)	②	08738	8	"1" set data for each bit.	Confirms setting (Settings are restored to memory when power is turned OFF.)
(in case of data memory)	③	08739	8	"1" is to write data into the memory for each bit.	Confirms setting and writes it to memory
Mode display switching	①	08702		"0" when nothing is displayed "1" when %/SEC is displayed "2" when TEMP is displayed "3" when x1000vs is displayed	Switches the display

• Only the sent address changes.  
 • Unsent addresses do not change.  
 -----  
 • Sets irradiation time by multiplying by 10.  
 In the case of 0.1 s  
 → "1" "  
 In the case of 0.0 1 s  
 → "100"  
 \* Please enter the value above in hexadecimal when writing the data.

# External control

	Procedure	Address	Bit	Data	Comments
Temperature display switching	①	08703	0	"1" when "C", "1" when "F"	Switches head temperature display units between "C/F".
(in case of data setting)	②	08738	5	"1" sets data for each bit.	Confirms the setting (setting is restored to memory when power is turned OFF)
(in case of data memory)	③	08739	5	"1" writes data to memory for each bit.	Confirms the setting and writes it to memory
Interlock	①	07005	0	Interlock ON/OFF switching command, "1" switches Interlock ON/OFF.	Locks the SET switch. Settings cannot be modified in this state.
(in case of data setting)	②	08738	7	"1" sets data for each bit.	Confirms the setting (setting is restored to memory when power is turned OFF)
(in case of data memory)	③	08739	7	"1" writes data to memory for each bit.	Confirms the setting and writes it to memory
Error reset	①	07005	0	Resets (on switch from "0" to "1")	Clears errors and returns controller to previous state.
CH1 total irradiation time setting	①	08710~08711	0	LED1 total irradiation time (higher byte), (lower byte)	Set CH1 cumulative irradiation time
(in case of data setting)	②	08738	0	"1" sets data for each bit.	Confirms the setting (setting is restored to memory when power is turned OFF)
(in case of data memory)	③	08739	0	"1" sets data to memory for each bit.	Confirms the setting and writes it to memory
CH2 total irradiation time setting	①	08712~08713	0	LED2 total irradiation time (higher byte), (lower byte)	Set CH2 cumulative irradiation time
(in case of data setting)	②	08738	1	"1" sets data for each bit.	Confirms the setting (setting is restored to memory when power is turned OFF)
(in case of data memory)	③	08739	1	"1" writes data to memory for each bit.	Confirms the setting and writes it to memory
CH3 total irradiation time setting	①	08714~08715	0	LED3 total irradiation time (higher byte), (lower byte)	Set CH3 cumulative irradiation time
(in case of data setting)	②	08738	2	"1" sets data for each bit.	Confirms the setting (setting is restored to memory when power is turned OFF)
(in case of data memory)	③	08739	2	"1" writes data to memory for each bit.	Confirms the setting and writes it to memory
CH4 total irradiation time setting	①	08716~08717	0	LED4 total irradiation time (higher byte), (lower byte)	Set CH4 cumulative irradiation time
(in case of data setting)	②	08738	3	"1" sets data for each bit.	Confirms the setting (setting is restored to memory when power is turned OFF)
(in case of data memory)	③	08739	3	"1" writes data to memory for each bit.	Confirms the setting and writes it to memory
CH1 head replacement time setting	①	08740~08741	0	LED1 replacement time setting values (higher byte), (lower byte)	Set CH1 replacement time setting values
(in case of data setting)	②	08739	9	"1" sets data for each bit.	Confirms the setting (setting is restored to memory when power is turned OFF)
(in case of data memory)	③	08739	9	"1" writes data to memory for each bit.	Confirms the setting and writes it to memory
CH2 head replacement time setting	①	08742~08743	0	LED2 replacement time setting (higher byte), (lower byte)	Set CH2 replacement time setting values
(in case of data setting)	②	08738	10	"1" sets data for each bit.	Confirms the setting (setting is restored to memory when power is turned OFF)
(in case of data memory)	③	08739	10	"1" writes data to memory for each bit.	Confirms the setting and writes it to memory
CH3 head replacement time setting	①	08744~08745	0	LED3 replacement time setting (higher byte), (lower byte)	Set CH3 replacement time setting values
(in case of data setting)	②	08738	11	"1" sets data for each bit.	Confirms the setting (setting is restored to memory when power is turned OFF)
(in case of data memory)	③	08739	11	"1" writes data to memory for each bit.	Confirms the setting and writes it to memory
CH4 head replacement time setting	①	08746~08747	0	LED4 replacement time setting values (higher byte), (lower byte)	Set CH4 replacement time setting values
(in case of data setting)	②	08738	12	"1" sets data for each bit.	Confirms the setting (setting is restored to memory when power is turned OFF)
(in case of data memory)	③	08739	12	"1" writes data to memory for each bit.	Confirms the setting and writes it to memory
Buzzer setting	①	08724	0	"1" sets buzzer to sound when an error occurs.	The buzzer will sound continuously when an error occurs.
			1	"1" sets buzzer to sound when SET switch is turned ON.	The buzzer will make a short sound when the SET switch is turned ON.
			2	"1" sets buzzer to sound when EMISSION switch is turned ON.	The buzzer will make a short sound when the EMISSION switch is turned ON.
			3	"1" sets buzzer to sound when MODE switch is turned ON.	The buzzer will make a short sound when the MODE switch is turned ON.
			4	"1" sets buzzer to sound when CH1-4 switch is turned ON.	The buzzer will make a short sound when the CH1-4 switch is turned ON.
			5	"1" sets buzzer to sound when UV/CHK switch is turned ON, or when external output or communication occurs.	The buzzer will make a short sound when the controller is switched to UV/CHK mode.
			6	"1" sets buzzer to sound when communication data changes and when writing to memory.	The buzzer will make a short sound when communication data is changed or written to memory.
			7	"1" sets buzzer to sound when external output or communication starts/stops.	The buzzer will make a short sound when external input or communication starts/stops.
			8	"1" sets buzzer to sound when ▲ switch is turned ON.	The buzzer will make a short sound when the ▲ switch is ON.
			9	"1" sets buzzer to sound when lock function is set.	The buzzer will make a short sound when the lock function is set.
			10	"1" sets buzzer to sound when calibration is completed.	The buzzer will make a short sound when calibration is completed.
			11	"1" sets buzzer to sound when power is turned ON.	The buzzer will make a short sound when the power is turned ON.
(in case of data setting)	②	08738	6	"1" sets data for each bit.	Confirms the setting (setting is restored to memory when power is turned OFF)
(in case of data memory)	③	08739	6	"1" writes data to memory for each bit.	Confirms the setting and writes it to memory

# External control

## Serial communication example

### (1) Read operation

• Example: Type 0 LED 1 strength check

[Command message transmission method]

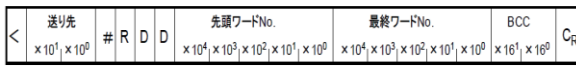

[Command message transmission example]

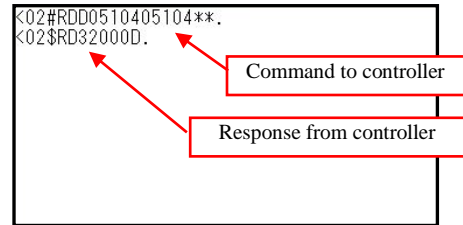
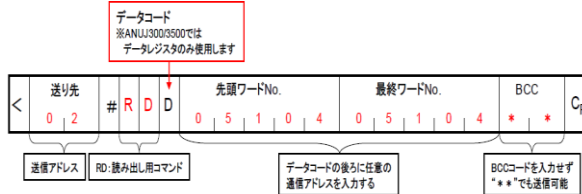

\* The values of a response message are displayed in hexadecimal.

### (2) Write operation

• Example: Type 0 LED 1 strength change

1. Enter the value you wish to change to the command in hexadecimal.

[Command message transmission method]

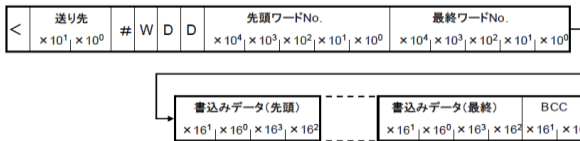

[Command message transmission example]

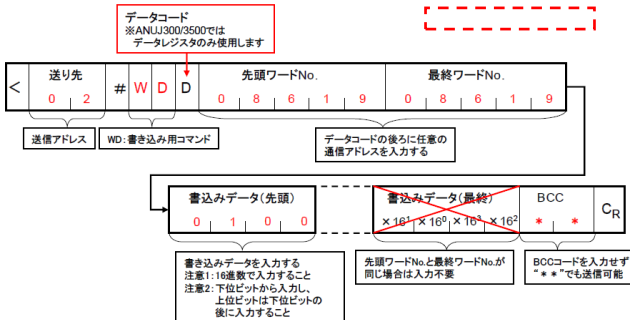

[Display screen]

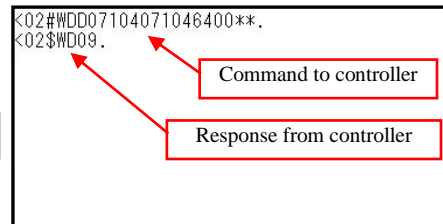

2. Save the contents changed

\* Note that the changed contents do not become effective unless performing the data setting (data memory).

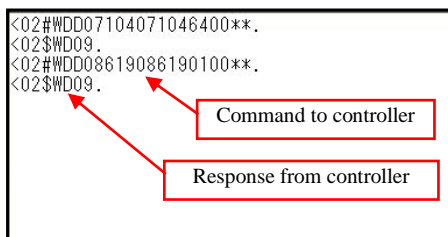

## 7.4 Setup tool application for UJ35

- Operation from a PC
  - Application can be downloaded from the web.
  - Compatible with Windows XP, Windows Vista, and Windows 7.



1. Open the Aicure UJ35 application

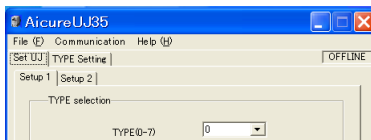

2. Select initial settings

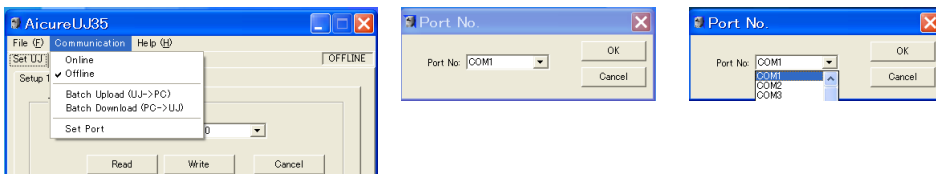

- Select the port for UJ35 controller connection (default setting is COM 1)

3. Using the Menu Bar

### 1) File (F)

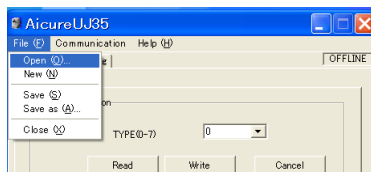

- |                  |  |
|------------------|--|
| • Open (O) ...   | Opens a UJ35 data file (*.acr).                      |
| • New (N)        | Cancels current settings to create new settings.     |
| • Save (S)       | Overwrites existing data file with current settings. |
| • Save as (A)... | Creates new data file with current settings.         |
| • Exit (X)       | Quits the application.                               |

# External control

## 2) Communication

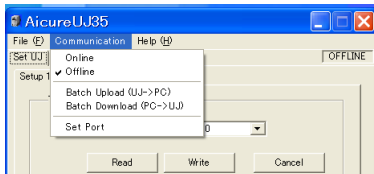

- Online Enables use of UV.CHK mode and AUTO mode.
- Offline Sets Aicure UJ35 offline when application is open.
- Batch Download(UJ->PC) Reads all data from UJ35 controller into computer.
- Batch Upload(PC->UJ) Writes existing settings data from computer to UJ35 controller.
- Set Port Selects the COM port for UJ35 controller connection.

## 3) Help (H)

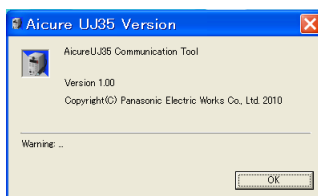
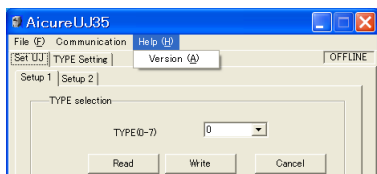

- Version (A) - Displays the version of the application software.

## 4. Using the operation setting screen

### [Settings 1]

- 1) Set UJ – Selects Type from 0 to 7 (does not switch CH selection).

\*During Type selection Type Change is highlighted.

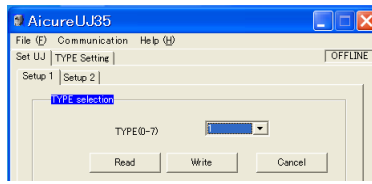
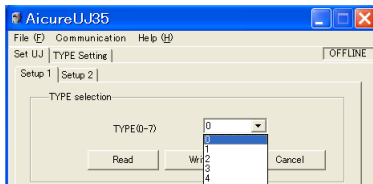
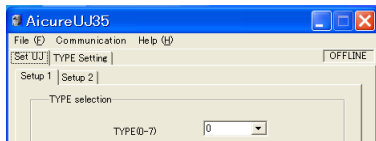

- Read Reads the current Type setting from UJ35 controller into computer.
- Write Uploads current Type from computer to UJ35 controller.
- Cancel Cancels current Type setting operation and return to start.

- 2) “Switch Display”... Switches the display mode of the controller.

\*Settable only when UJ35 controller is online.

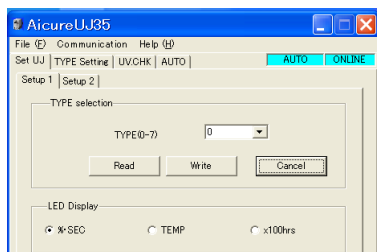

- “%/ SEC” For display of irradiation intensity and time.
- “TEMP” For display of head temperature.
- “x100hrs” For display of lifetime setting and cumulative irradiation time.

3) “INTERLOCK”... Locks and unlocks the UJ35 controller settings.

\*Settable only when UJ35 controller is online.

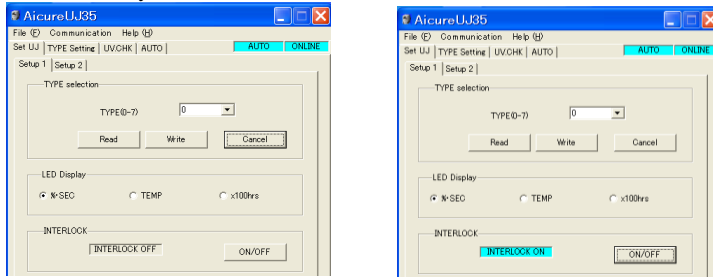

- [INTERLOCK OFF] Switches interlock off (state on UJ35 controller side)
- [INTERLOCK ON] Sets interlock ON (highlighted on screen) (state on UJ35 controller side)
- ON/OFF Toggles UJ35 controller interlock ON and OFF

4) “Cumulative irradiation time (×100hrs)”... To set the cumulative irradiation time

(\*During setting “Cumulative irradiation time (×100hrs)” is highlighted.)

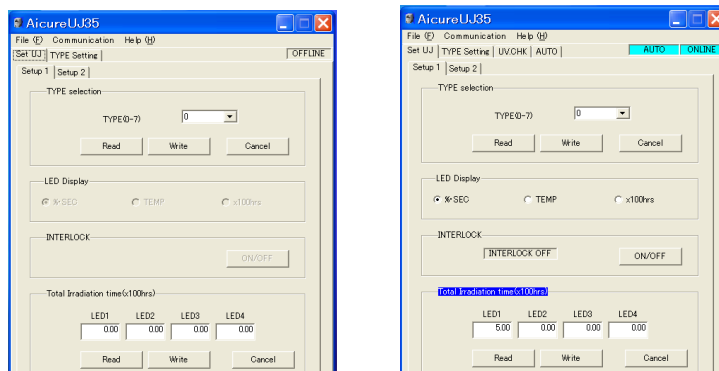

- Read Reads the current value of cumulative irradiation time from the UJ35 controller into the PC.
- Write Uploads the current cumulative irradiation time from the PC to the UJ35 controller.
- Cancel Cancels the current cumulative irradiation time setting operation and reverts to the original settings.

[Settings 2]

1) “Set MODE”... To switch the mode of the controller

(\*While changing mode settings, the modes, “TEMP,” “OUTPUT,” and “Buzzer OFF” are highlighted.)

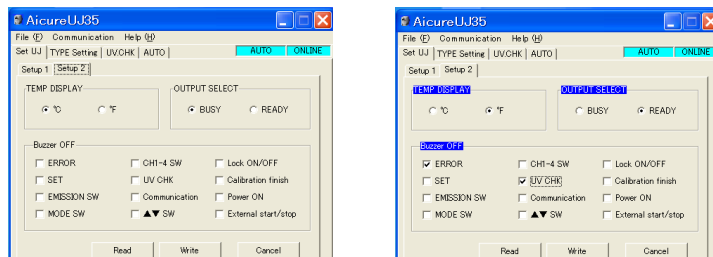

- [TEMP] Switches head temperature display between °C/°F.
- [OUTPUT] Switches external output signals between READY/BUSY.
- [Buzzer OFF] Switches the buzzer ON/OFF for each operation.
- Read Reads the MODE settings from the UJ35 controller into the PC.
- Write Uploads the MODE settings from the PC to the UJ35 controller.
- Cancel Cancels the current MODE setting operation and reverts to the original settings.

# External control

2) “Replacement time (×100hrs)”... To set the LED replacement time

(\* While changing replacement time settings, “Replacement time (×100hrs)” is highlighted.

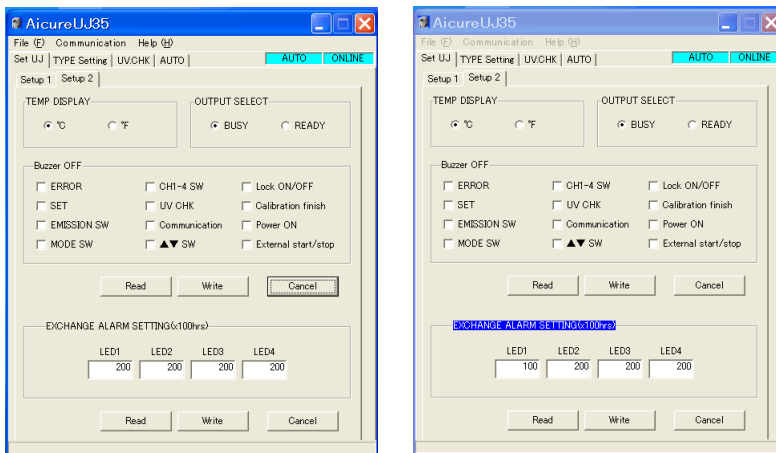

- Read Reads the current replacement time setting from the UJ35 controller into the PC.
- Write Uploads the current replacement setting from the PC to the UJ35 controller.
- Cancel Cancels the current replacement time setting operation and reverts to the original settings.

## 5. Using the Type Set screen

... For particular Type 0-7), select the CH.

... For particular Type (0-7), enter the program settings (STEP (% , s) for particular CH (1-4).

\*When new CH settings are being entered, Type Change is highlighted.

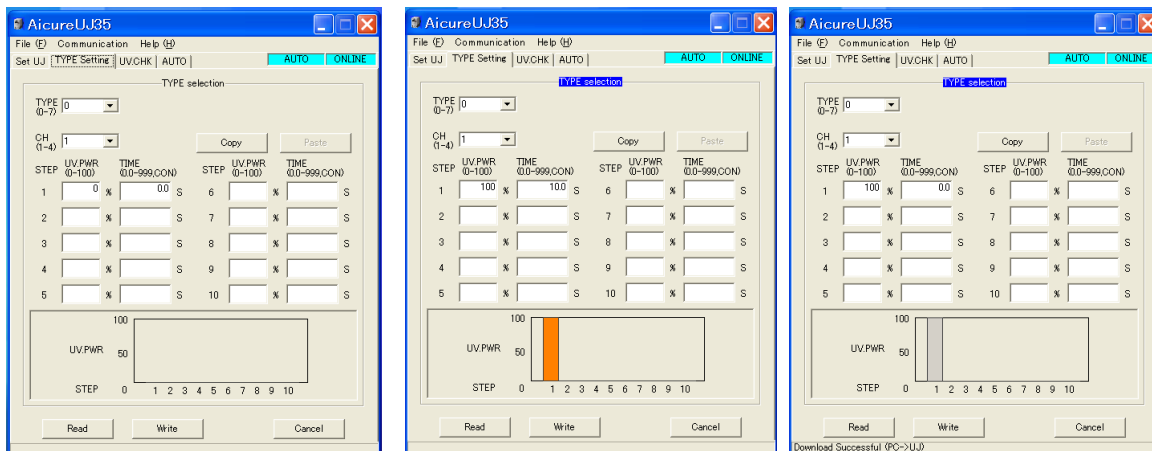

Lower graph: orange bar, irradiation enabled timing; gray bar, irradiation disabled timing

- [TYPE(0-7)] Selects particular TYPE (0–7) for setting and read out.
- [CH(1-4)] Selects particular TYPE CH (1–4) for setting and read out.
- [UV.PWR(0-100)] For each STEP (1–10) enter UV strength (0%–100%) or display values read from UJ35 controller.
- [TIME(0.0-999, CON)] For each STEP (1–10) enter irradiation time (0–999 s, CON) or display values read from UJ35 controller.
- Copy Copies settings for STEP 1–10.
- Paste Pastes copied settings for STEP 1–10.
- Read Reads the current TYPE CH (CH1 only) settings from the UJ35 controller.
- Write Uploads current TYPE CH (CH1 only) settings and CH selection from computer to UJ35 controller.
- Cancel Cancels current setting entry operation and return to start.

## 6. Using the AUTO screen (only available in online mode)

- ... Displays all UJ35 controller information in real time.
- ... Enables irradiation START/STOP and emergency STOP control from computer.

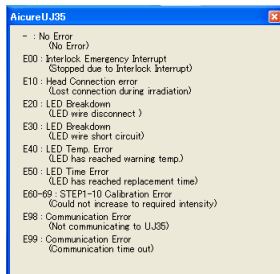
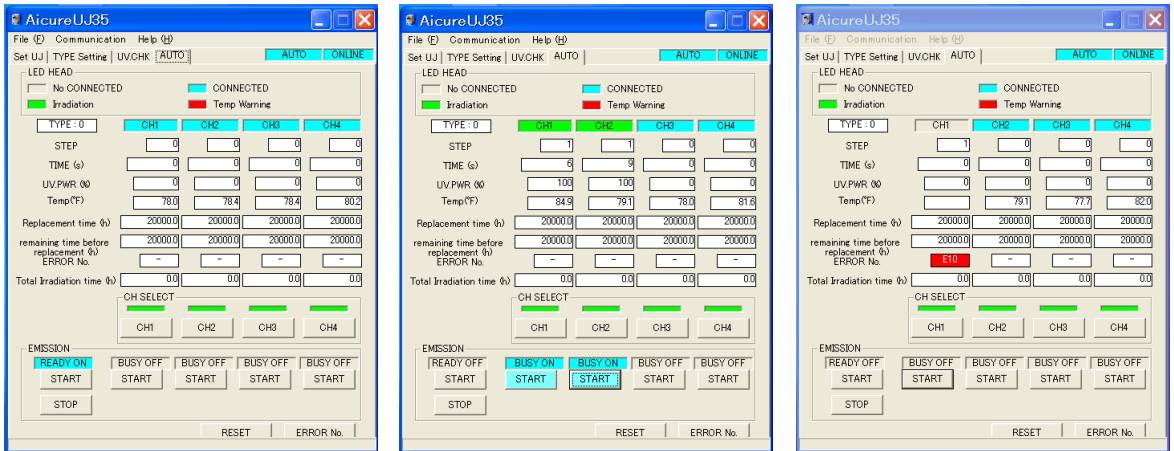

- LED status for each CH differentiated by color
- When irradiation is possible, READY ON is highlighted
- If an error occurs, an error number is displayed
- Panel showing error list can be displayed at any time
- During irradiation START is highlighted

- [TYPE] Shows current TYPE (0-7).
- [STEP] During irradiation, current STEP is displayed.
- [TIME(s)] During irradiation, counts down the time remaining from the value that was set for the current STEP.  
Continuous irradiation: Indicates the total irradiation time (so far) for the current step
- [UV.PWR(%)] During irradiation shows the UV strength for the current STEP.
- [TEMP.] Constantly shows the LED temperature for each connected CH.
- [Replacement time(h)] Shows the LED head replacement time setting
- [Remaining time before replacement (h)] Shows remaining LED head life to when replacement is necessary.
- [ERROR No.] When an error occurs, error number is displayed.
- [Total Irradiation time (h)] Shows cumulative time that LED head has been ON.
- [CH SELECT] Uploads CH selection to the UJ35 controller.
- BUSY ON/OFF Indicates BUSY ON/OFF status of each channel.
- READY ON/OFF Indicates READY ALL ON/OFF status.  
Also, indicates READY ON/OFF status of each channel.
- START Starts irradiation on all selected channels together.  
Also used to start irradiation on individual channels.
- STOP During irradiation, performs emergency stop.
- RESET Resets errors.
- ERROR No. Displays error list panel.

---If Batch Download (Communication menu) is executed, values set in UJ35 controller are displayed.

# External control

## 7. Using the UV.CHK screen (only available in online mode).

- ... Displays all UJ35 controller information in real time.
- ... Enables measurement calibration of optional UV sensor and set UV strength values.

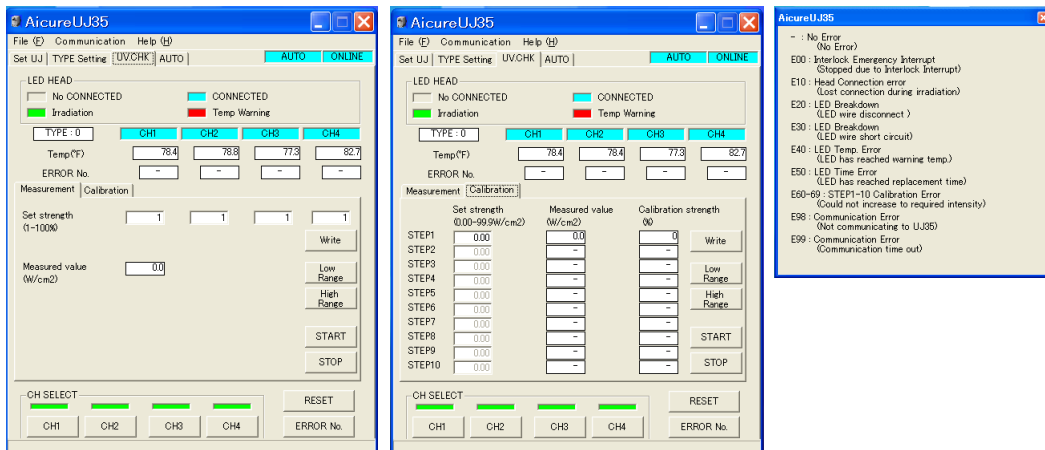

- LED status for each CH differentiated by color
- If an error occurs, an error number is displayed
- Panel showing error list can be displayed at any time
- Shows measured value in real time

- [TYPE] Displays the current TYPE (0-7).
- [TEMP.] Constantly shows the LED temperature for each connected CH.
- [ERROR No.] Displays error list panel.

### 1) "Measurement"... Shows measured UV strength of selected CH.

\*When values are being changed for a CH (1-4), Set strength (1-100) is highlighted.

- [CH SELECT] Selects the CH to be measured.
- [Set strength (1-100%)] Enables entry of strength (%) to be measured, can be changed during measurement.
- [Measured value (W/cm<sup>2</sup>)] Shows measured value in real time.
- Write Uploads UV entered strength (%) to UJ35 controller.
- Low Range Sets measurement range to 0.00-9.99 W/cm<sup>2</sup>.
- High Range Sets measurement range to 0.0-49.9 W/cm<sup>2</sup>.
- START Starts irradiation on the selected CH.
- STOP During irradiation, performs emergency stop.

### 2) "Calibration"... For the selected TYPE, corrects the UV strength for CH and STEP.

- [CH SELECT] Selects the CH to be calibrated.
- [Set strength (0.00-49.9W/cm<sup>2</sup>)] Enables entry of strength (%) to be calibrated.
- [Measured value (W/cm<sup>2</sup>)] Shows measured strength in real time.
- [Calibration strength (%)] Shows strength (%) during calibration.
- Write Uploads UV entered strength (%) to UJ35 controller.
- Low Range Sets measurement range to 0.00-9.99 W/cm<sup>2</sup>.
- High Range Sets measurement range to 0.0-49.9 W/cm<sup>2</sup>.
- START Starts irradiation for calibration.
- STOP Performs emergency stop during calibration.
- RESET Resets errors.
- ERROR No. Displays error list panel.

## 8 Warning indications

In the event of an error during irradiation, a warning will be displayed on the display panel of the controller (in operation mode).

### ■ Temperature warning

When the LED head temperature reaches the warning level during irradiation in operation mode, “TEMP” (units indicator) will start to flash, and the LED lights next to the switch of the affected channel will turn orange (mixture of green and red) and the external output signal “ALARM” will be turned ON.



#### Temperature warning

When the measured LED head temperature reaches the warning level, “TEMP” (units indicator) will start to flash, and the LED light next to the switch of the affected channel will turn orange. When the temperature reaches an abnormal level, an error code (E40) will be displayed and the buzzer will sound, and the external output signal “ERROR” will be turned ON. When the temperature drops below the abnormal level the warning is cleared and the warning indicators will change back to green. If the color does not change to green for a considerable time, there may be a problem with the LED temperature detection line, such as a short-circuit. In this case, remove the LED head and the connection cable from the connector and check the wiring.

### ■ Time warning

When the warning time is reached in operation mode during irradiation, “×100hrs” (units indicator) will start to flash, and the “ALARM” external output signal will be turned ON. After the time warning is detected, “×100hrs” will continue to be displayed until the cumulative time (head management item) is reset.



#### Time warning

When the cumulative total irradiation time of an LED head reaches to within 30 hours of the set LED replacement time, “×100hrs” (units indicator) will start to flash. When the LED replacement time is reached, an error (E50) will be displayed and the buzzer will sound, and the external output signal “ERROR” will be turned ON. To reset after this error, hold down the “SET” switch. This will reset the controller and turn OFF the buzzer and “ERROR” output signal, but the error code will still be displayed. The error display will be cleared only after replacing the LED head and resetting the cumulative time.

If irradiation is continued without replacing the LED head, the error message (E50) will be displayed again and the buzzer will sound.

\* To check which channels are subject to time warnings, switch the display mode to show cumulative irradiation time (×100hrs) for the channel. If the “×100hrs” indicator is flashing, the channel is under a time warning.

# Warning indications

## ■ Error codes

When an error occurs, the three-digit display will indicate the error code.

Display	Error name	Error description
E00	Interlock emergency stop	The interlock contact was opened during irradiation.
CH1-4 E10	Connection error	The LED head was disconnected.
CH1-4 E20	LED break error	A circuit break was detected in the LED head during irradiation.
CH1-4 E30	LED short-circuit error	A short-circuit of the LED head was detected during irradiation.
CH1-4 E40	LED temperature error	The LED head temperature reached an abnormal level.
CH1-4 E50	LED time error	The cumulative time of the LED has reached the set replacement time.
CH1-4 E60	STEP1 calibration error	The set UV intensity was not reached.
CH1-4 E61	STEP2 calibration error	
CH1-4 E62	STEP3 calibration error	
CH1-4 E63	STEP4 calibration error	
CH1-4 E64	STEP5 calibration error	
CH1-4 E65	STEP6 calibration error	
CH1-4 E66	STEP7 calibration error	
CH1-4 E67	STEP8 calibration error	
CH1-4 E68	STEP9 calibration error	
CH1-4 E69	STEP10 calibration error	



## 9 Safety measures

---

### 9.1 Safety circuit

Aicure UJ35 is equipped with a safety circuit, which functions as follows, in case of a malfunction or accident.

- 1) If the cable between the LED head and the controller is broken, an error signal will be output and an error screen displayed.
- 2) If the LED head is short-circuited, an error signal will be output and an error screen displayed.
- 3) If the LED head temperature becomes excessively high, a warning signal will be output with a warning screen displayed.
- 4) If 5 V and GND are shorted by mistake during external terminal connections, the 5 V circuit will stop operation. When the short circuit is removed, the controller will automatically recover. Note, however, that if the short-circuited state lasts for an extended period, this product may be damaged.

## 10.1 Outline of specifications

### ■ Controller specifications

Item	ANUJ3000	ANUJ3000-NC	ANUJ3500	ANUJ3500-NC
No. of connected heads	1-4 heads			
UV sensor connection	Not supported		1 (special UV sensor for ANUJ3800, sold separately)	
UV irradiation	Simple mode, 1 pattern irradiation All heads together/separately		Simple mode, 1 pattern, and programmed pattern irradiation (max. 10 steps, 7 patterns) All heads together/separately	
Type switching	No (1 type)		Yes (8 types) Stores up to 7 types of irradiation pattern Type switching by external control	
Modulation/irradiation control	Digital modulation: 0-100% (1% increments) Continuous (CON) or timer-based (0.1-99.9 s, 100-999s) irradiation control			
Timer precision	+0.04s			
Settings/operation	Settings via operation switches Power supply key switch		Settings via operation switches Power supply key switch Settings via RS-232C (UJ35 setting tool)	
Default settings	Buzzer ON/OFF, BUSY/READY output, and °C/°F LED temperature display can all be switched (Default values: Buzzer ON, BUSY output, °C temperature LED display)			
Display	Large 7-seg LED display: Irradiation time, LED head temperature (°C or °F units, switchable), cumulative time, error codes, UV intensity (UJ35) Small 7-seg LED display: Modulation, replacement time, UV measurement modulation (UJ35), calibration measurement UV intensity (UJ35)			
LED head temperature display	Displays LED temperature of each head			
External control	Format	Parallel I/O		RS-232C*1 Parallel I/O
	Ext. input	Individual irradiation, irradiation stop, all irradiation, interlock, UV CHK (UJ35), type switching (UJ35), max. 28 V DC rating, 100 mA (per input)		
	Ext. output	READY ALL, BUSY/READY for each head (switchable), warnings, errors, +5 V (max. 250 mA)		
Power supply voltage	Main Unit	5.95 V DC , Current.:6A		
	AC adapter	100 to 240 V AC±10% , Frequency:50/60 Hz , Current.:1.2A		
	Power cable	100V AC		100V AC
Power consumption	60 VA (at 100 V AC)			
overvoltage category	• AC adapter	Overvoltage category II		
	• Main unit	Overvoltage category I		
Operating temperature/humidity range	0 to +35°C, 30 to 85% RH (at 25°C, no condensation)			
Storage temperature/humidity range	-10 to +60°C, 30 to 85% RH (at 25°C, no condensation)			
Noise resistance	1,500 V pulse width 50 ns/1 μs (using noise simulator method)			
Vibration resistance	10-55 Hz, total amplitude of 0.75 mm, 30 minutes each in direction of X, Y, and Z			
Shock resistance	294 m/s <sup>2</sup> , 5 times each in direction of X, Y, and Z			
Insulation resistance (default value)	100 MΩ or more (500 V DC by insulation resistance tester) Between AC adapter (primary) and FG of controller, between AC adapter (primary) and parallel I/O			

# Specifications

Voltage resistance (default value)	1,500 V AC/1 minute, cutoff current of 10 mA Between AC adapter (primary) and FG of controller, between AC adapter (primary) and parallel I/O			
Protective structure	IPx0(Design equivalent to IP30)			
Usage place	Indoor space			
Pollution degree	Pollution degree 2			
Altitude	Up to 2000m			
Weight	Approx. 1,290 g		Approx. 1,310 g	
	Controller:940g AC adapter:350g		Controller:960g AC adapter:350g	
Accessories	AC adapter, keys (2), INSTRUCTION MANUAL			
	Japan PSE standards compatible power cable (100 V AC)		Japan PSE standards compatible power cable (100 V AC)	

\*1: Serial communication specifications (ANUJ3500, ANUJ3500-NC only)

RS-232C	Communications method: asynchronous, transmission speed: 38,400 bps
	Connector: D-sub 9-pin connector (male pins)

## ■ Head specifications ANUJ6180 series

(Note) The LED head is a set with the controller and complied with the CE marking.

### Standard head

Item		ANUJ6180				
Lenses	Spot diameter	φ 3mm	φ 4mm	φ 6mm	φ 8mm	φ 10mm
	Lens model	ANUJ6423	ANUJ6424	ANUJ6426	ANUJ6428	ANUJ6420
UV intensity (mW/cm <sup>2</sup> ) *1		12500*2	10600*2	4720	2500	580
Working distance		10mm	12mm	20mm	25mm	30mm
Light source		Max. output: 990 mW, wavelength: 365±5 nm, Class 3B, LED				
Operating temperature/humidity range		+5 to +35°C, 30 to 85% RH (at 25°C, no condensation)				
Storage temperature/humidity range		-10 to +60°C, 30 to 85% RH (at 25°C, no condensation)				

Item		ANUJ6184				
Lenses	Spot diameter	φ 3mm	φ 4mm	φ 6mm	φ 8mm	φ 10mm
	Lens model	ANUJ6423	ANUJ6424	ANUJ6426	ANUJ6428	ANUJ6420
UV intensity (mW/cm <sup>2</sup> ) *1		14700*2	11700*2	5800*2	2790*2	590
Working distance		10mm	12mm	20mm	25mm	30mm
Light source		Max. output: 1180 mW, wavelength: 385±5 nm, Class 3B, LED				
Operating temperature/humidity range		+5 to +35°C, 30 to 85% RH (at 25°C, no condensation)				
Storage temperature/humidity range		-10 to +60°C, 30 to 85% RH (at 25°C, no condensation)				

Item		ANUJ6187				
Lenses	Spot diameter	φ 3mm	φ 4mm	φ 6mm	φ 8mm	φ 10mm
	Lens model	ANUJ6423	ANUJ6424	ANUJ6426	ANUJ6428	ANUJ6420

# Specifications

UV intensity (mW/cm <sup>2</sup> ) *1	15500*2	12600*2	5730*2	3150*2	890*2
Working distance	10mm	12mm	20mm	25mm	30mm
Light source	Max. output: 1530 mW, wavelength: 405±5 nm, Risk Group 2, LED				
Operating temperature/humidity range	+5 to +35°C, 30 to 85% RH (at 25°C, no condensation)				
Storage temperature/humidity range	-10 to +60°C, 30 to 85% RH (at 25°C, no condensation)				

## Smart head

Item		ANUJ6186				
Lenses	Spot diameter	φ 3mm	φ 4mm	φ 6mm	φ 8mm	φ 10mm
	Lens model	ANUJ6423	ANUJ6424	ANUJ6426	ANUJ6428	ANUJ6420
UV intensity (mW/cm <sup>2</sup> ) *1	17200*2		14940*2	7560	4450	1360
Working distance	8mm		10mm	15mm	20mm	30mm
Light source	Max. output: 990 mW, wavelength: 365±5 nm, Class 3B, LED					
Operating temperature/humidity range	+5 to +35°C, 30 to 85% RH (at 25°C, no condensation)					
Storage temperature/humidity range	-10 to +60°C, 30 to 85% RH (at 25°C, no condensation)					

Item		ANUJ6188				
Lenses	Spot diameter	φ 3mm	φ 4mm	φ 6mm	φ 8mm	φ 10mm
	Lens model	ANUJ6423	ANUJ6424	ANUJ6426	ANUJ6428	ANUJ6420
UV intensity (mW/cm <sup>2</sup> ) *1	19500*2		16920*2	8680*2	4750*2	1400*2
Working distance	8mm		10mm	15mm	20mm	30mm
Light source	Max. output: 1180 mW, wavelength: 385±5 nm, Class 3B, LED					
Operating temperature/humidity range	+5 to +35°C, 30 to 85% RH (at 25°C, no condensation)					
Storage temperature/humidity range	-10 to +60°C, 30 to 85% RH (at 25°C, no condensation)					

Item		ANUJ6189				
Lenses	Spot diameter	φ 3mm	φ 4mm	φ 6mm	φ 8mm	φ 10mm
	Lens model	ANUJ6423	ANUJ6424	ANUJ6426	ANUJ6428	ANUJ6420
UV intensity (mW/cm <sup>2</sup> ) *1	20900*2		17800*2	9190*2	5450*2	1790*2
Working distance	8mm		10mm	15mm	20mm	30mm
Light source	Max. output: 1530 mW, wavelength: 405±5 nm, Risk Group 2, LED					
Operating temperature/humidity range	+5 to +35°C, 30 to 85% RH (at 25°C, no condensation)					
Storage temperature/humidity range	-10 to +60°C, 30 to 85% RH (at 25°C, no condensation)					

\*1: Fixed to a metal head fixture at an ambient temperature of 25 ° C and with 100% output.

\*2: Decayed at the filter, measured, converted, and then calculated.

■ UV sensor specifications

Item		ANUJ3800
UV intensity measurement range	High range	0 to 49.9 W/cm <sup>2</sup> (min. reading 0.1 W/cm <sup>2</sup> )
	Low range	0 to 9.99 W/cm <sup>2</sup> (min. reading 0.01 W/cm <sup>2</sup> )
Measurement precision		±5% (+5 to +35°C) ±1% (at 25°C, repeatability)
Data communication		RS-422 level communication, proprietary format, 9,600 bps
Power supply voltage		8.1 to 13.2 V DC
Power consumption		≤ 30 mA
Operating temperature/humidity range		+5 to +35°C, 30 to 85% RH (at 25°C, no condensation)
Storage temperature/humidity range		-10 to +60°C, 30 to 85% RH (at 25°C, no condensation)
Connector		mini-DIN connector (TECHNICAL DENSHI D6-175J-201)
Weight		Approx. 220 g (Body + sensor head + 2 m connection cable) Approx. 350 g (incl. packaging)
Accessories		2 m connection cable, INSTRUCTION MANUAL

# Dimensions

UJ35 Controller  
ANUJ3500  
(Weight: About 960g)

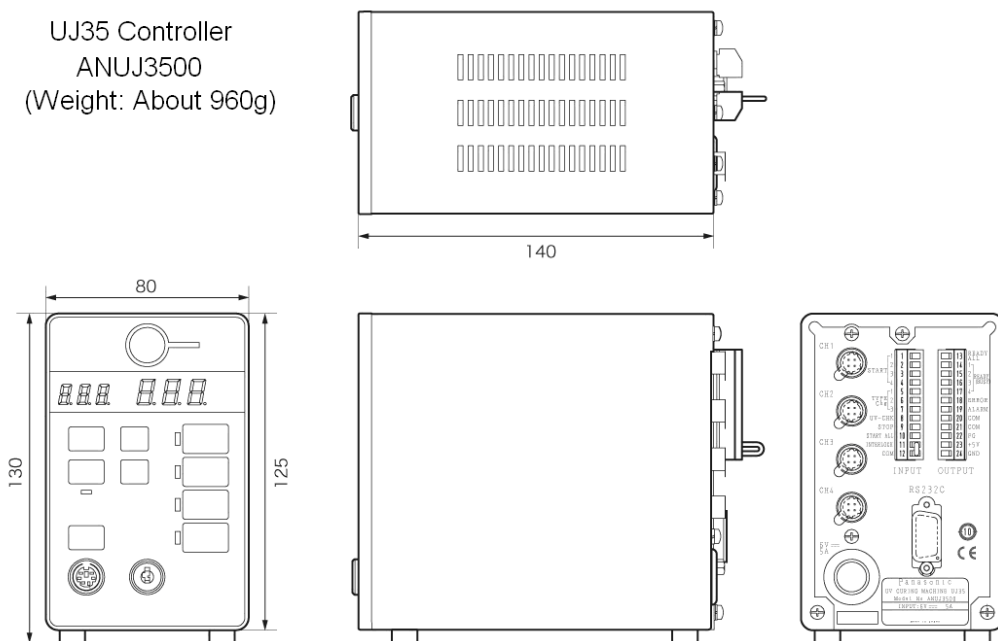

Connection cable  
ANUJ6220

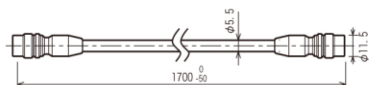

ANUJ6180 / ANUJ6184 / ANUJ6186 / ANUJ6187 /  
ANUJ6188 / ANUJ6189

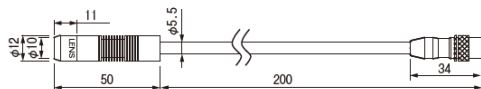

Standard and Cylindrical lens Rod lens ANUJ6467L

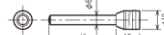

Protective glass  
ANUJ6430

Side view lens

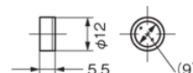

UV sensor ANUJ3800

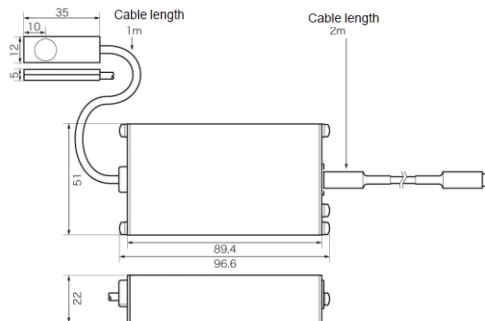

Mounting bracket for head  
ANUJ6804

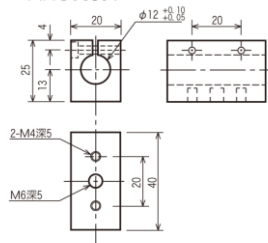

## 12.1 Options and spare parts

### 1) Controller

Name	Description	Product number
UJ30 controller (for Japan)	4 head connection (incl. AC adapter + power cable)	ANUJ3000 *1
UJ30 controller (for outside Japan)	4 head connection (incl. AC adapter)	ANUJ3000-NC
UJ35 controller (for Japan)	4 head connection (incl. AC adapter + power cable) RS-232C communication, supports UV sensor (specially for UJ35)	ANUJ3500 *1
UJ35 controller (for outside Japan)	4 head connection (incl. AC adapter) RS-232C communication, supports UV sensor (specially for UJ35)	ANUJ3500-NC

\*1: When you take this product including the power cable out of Japan, please observe the laws and regulations related to export control outside Japan.

### 2) Heads ANUJ6180 Series

Name	Description	Product number
Standard head *2	$\phi 12 \times L50$ mm head (cable length 200 mm), 365 nm	ANUJ6180
	$\phi 12 \times L50$ mm head (cable length 200 mm), 385 nm	ANUJ6184
	$\phi 12 \times L50$ mm head (cable length 200 mm), 405 nm	ANUJ6187
Smart head *2	$\phi 12 \times L50$ mm head (cable length 200 mm), 365 nm	ANUJ6186
	$\phi 12 \times L50$ mm head (cable length 200 mm), 385 nm	ANUJ6188
	$\phi 12 \times L50$ mm head (cable length 200 mm), 405 nm	ANUJ6189

\*2: For connection to a controller, a connection cable is needed (sold separately).

### 3) Lenses

Name	Description	Product number
Standard lens	$\phi 3$	ANUJ6423
	$\phi 4$	ANUJ6424
	$\phi 6$	ANUJ6426
	$\phi 8$	ANUJ6428
	$\phi 10$	ANUJ6420
Side-view lens	$\phi 6$ , angle $90^\circ$	ANUJ6426SV
	$\phi 8$ , angle $90^\circ$	ANUJ6428SV
	$\phi 10$ , angle $90^\circ$	ANUJ6420SV
Cylindrical lens	Cylindrical, R5	ANUJ6450S
	Cylindrical R7.5	ANUJ6475S
Rod lens	$\phi 4$ R7 L=43mm	ANUJ6447L *3
	$\phi 6$ R7 L=43mm	ANUJ6467L
Protective glass		ANUJ6430

\*3: ANUJ6447L cannot equip the ANUJ6186/ANUJ6188.

## 12 Option and spare parts list

---

### 4) Connection cables

Name	Description	Product number
Connection cable	1.7 m, cable diameter: 5.5 mm	ANUJ6220
	3.0 m, cable diameter: 5.5 mm	ANUJ6230
	5.0 m, cable diameter: 7.6 mm	ANUJ6250
	7.0 m, cable diameter: 7.6 mm	ANUJ6270
	10.0 m, cable diameter: 7.6 mm	ANUJ6200

### 5) Options and spare parts

Name	Description	Product number
UV sensor	Special UV sensor for UJ35 controller	ANUJ3800
AC adapter cable set (for Japan)	100 to 240 V AC adapter Japan PSE standards compatible power cable (100 V AC) included	ANUJ6802 *4
Power cable for China	China CCC standards compatible power cable (220V AC) for ANUJ6802,6809	ANUJ6803 *5
Mounting bracket	Split type	ANUJ6804
Power cable for Taiwan	Taiwan BSMI standards compatible power cable (110V AC) for ANUJ6802,6809	ANUJ6808 *5
AC adapter	100 to 240 V AC adapter	ANUJ6809

\*4: When you take this product including the power cable out of Japan, please observe the laws and regulations related to expert control outside Japan.

\*5: Primary-side A-type plug.

Since this product is not PSE Mark compliant, it cannot be connected to a lamp line in Japan.

## 12.2 How to replace the lens unit

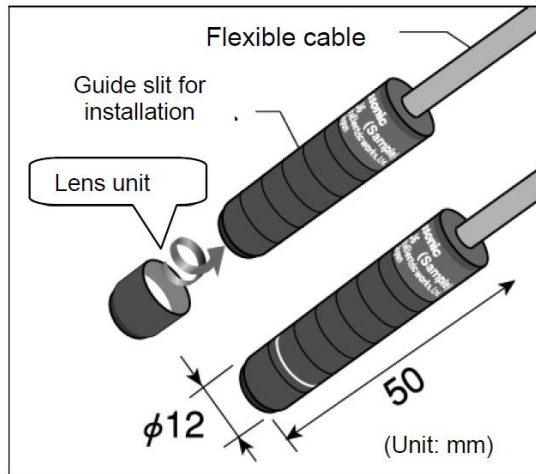

- 1) Rotate the lens unit to attach it to the LED head.  
(Tightening torque: 0.2 Nm)
- 2) Stick on the included seal to prevent looseness.

### Warning

- When attaching a lens unit, take care to prevent any dirt or other foreign substance from getting inside.
- Do not touch the lens with bare hands. If you touch the lens or if the lens becomes dirty, clean the lens by wiping with a soft cloth dipped in alcohol.

## 12.3 Fitting the mounting bracket

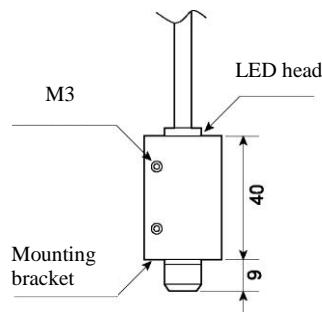

- 1) Insert the LED head into the mounting bracket.
- 2) Tighten the 2 torque screws to fix the LED head.  
(Tightening torque: 1 Nm)

### Warning

When you fix the LED head directly using some jigs (such as set screws) other than the mounting hardware, fix the LED head itself, rather than the lens unit.

## 13 Troubleshooting

Symptoms	Checks/Remedies
LED does not irradiate.	<p>Did you select the target channel for the product type? (When selected, the channel switch is lit or flashing.)</p> <p>→Select the target channel when setting the product type.</p> <p>If the target channel is selected but does not irradiate, check if the irradiation time is set to 0.0sec for the channel program for the target product type.</p> <p>→If so, set the irradiation time to 0.0sec or longer.</p>
When a warning message is displayed:	
Temperature warning	<p>The channel connection indicator changes to orange (mixture of green and red) when the LED head temperature has reached the warning level. If you continue the operation in this condition, the product life will be significantly shortened, and the temperature may exceed the upper limit, causing an emergency stop.</p> <p>→Set the UV intensity level (%) lower or improve the heat radiation performance of the LED head to keep the temperature lower than the warning level.</p>
Time warning	<p>When the total irradiation time of the LED reaches the point 30 hours before the preset LED replacement point, the time warning is issued and “x100hrs” will be lit. When the time reaches the LED replacement point, the irradiation process will make an emergency stop.</p> <p>→Prepare a new LED head. After replacement, clear the total irradiation time.</p>
When an error occurs:	
Interlock emergency stop (E00) “The interlock contact was opened during irradiation.”	<p>The emergency stop contact was opened during irradiation.</p> <p>→Check the emergency stop contact or the external input terminal block. Close the contact and then restart irradiation.</p> <p>* If the emergency stop contact is open, normal resetting is not available. Hold down SET to forcibly reset the interlock.</p>
Connection error (E10) “The LED was disconnected during irradiation.”	<p>It is possible that the connection cable or LED head was broken.</p> <p>→Reset the error status, check the connection of the cable and LED head with the channel in question, and replace them if necessary.</p>
LED wire broken (E20) “LED circuit opening was detected during irradiation.”	<p>The current detection was stopped during irradiation. It is possible that the connection cable or LED head was broken.</p> <p>→Reset the error status, check the connection of the connection cable and LED head with the channel in question, and replace them if necessary.</p>
LED short-circuited (E30) “LED short-circuiting was detected during irradiation.”	<p>An overcurrent was detected during irradiation. It is possible that the connection cable or LED head was short-circuited.</p> <p>→Reset the error status, check the connection of the cable and LED head with the channel in question, and replace them if necessary.</p>
LED temperature error (E40) “The LED temperature reached an abnormal temperature.”	<p>The LED temperature exceeded the upper limit.</p> <p>→Set the UV intensity level (%) lower or improve the heat radiation performance of the LED head to keep the temperature lower than the warning level.</p>
LED time error (E50) “The total irradiation time reached the replacement point.”	<p>The total irradiation time of the LED reached the preset LED replacement point. (Or, it is possible that the LED replacement point was set ahead the total irradiation time.)</p> <p>→Reset the error status, replace the LED head, and then clear the total irradiation time. (Or, go to the mode setting screen and correctly set the LED replacement point.)</p>
LED calibration error (E60 to E69) “Calibration uncompleted”	<p>Calibration was stopped before completion. Or, the calibration was not successful. It is possible that the setting is too high, or there is a problem in the dedicated UV sensor (option).</p> <p>→Reset the error status, check the connection of the UV sensor, review the setting, and then retry calibration.</p>

## Manual revision history

---

Manual No.	Issued	Revision Details
ARCT1F510E	2010.05	Initial version
ARCT1F510E-1	2010.10	2 <sup>nd</sup> edition
ARCT1F510E-2	2011.9	3 <sup>rd</sup> edition
ARCT1F510E-3	2013.4	4 <sup>th</sup> edition
ARCT1F510E-4	2013.12	5 <sup>th</sup> edition
ARCT1F510E-5	2020.9	6 <sup>th</sup> edition

---

## **Panasonic Industrial Devices SUNX Co., Ltd.**

■ Overseas Sales Division (Head Office):2431-1 Ushiyama-cho, Kasugai-shi, Aichi, 486-0901, Japan  
■ Telephone: +81-568-33-7861 ■ Facsimile: +81-568-33-8591  
[panasonic.net/id/pidsx/global](http://panasonic.net/id/pidsx/global)

About our sales network, please visit our website.

©Panasonic Industrial Devices SUNX Co., Ltd.2012-2020

September, 2020