



<b>Title</b>	IFA-600-AUCME3: Optical Device Alignment/Bonding System (Rev.09)
<b>Author</b>	Howoon Chung
<b>Date</b>	February 10, 2026
<b>Revision history</b>	<p>Rev.09: Feb. 10, 2026</p> <ul style="list-style-type: none"> <li>• Corrected power consumption: 1200 VA max. -&gt; 1100 VA max.</li> <li>• Corrected voltage requirement: 100 ~ 230 VAC -&gt; 100 ~ 240 VAC</li> <li>• Corrected manual stage information for the rear camera ass’y: 3-axis manual stages -&gt; 2-axis manual stages</li> <li>• Corrected minor typos</li> </ul> <p>Rev.02: Jan. 28, 2026</p> <ul style="list-style-type: none"> <li>• Added location of the rotation center for each fixture (2.3. )</li> <li>• Corrected travel range of fiber tip, center of fiber block, center of the lens (2.3. )</li> <li>• Added travel range of electric probe tip (2.3.9. )</li> <li>• Corrected alignment stability performance for lensed fiber-to-lensed fiber (2.1.2. )</li> <li>• Corrected stage direction on S1 stage assembly (2.3.1. )</li> <li>• Corrected typo of the rear camera description (2.6. )</li> <li>• Corrected the controllable axis count for the SC7000 (2.13.1. )</li> <li>• Corrected document revision format</li> </ul> <p>Rev.01: Jan. 25, 2026</p> <ul style="list-style-type: none"> <li>• For internal review</li> </ul>

# 1. Introduction

IFA-600-AUCME3 (hereinafter, IFA-600) is an automatic alignment/bonding/test system for optical devices. The features of the system are:

- Total 24 motorized stages including 21 high precision motorized stages for active alignment
  - 6-axis alignment stage assemblies (Left, Right, S1)
  - 3-axis center stage assembly
- 3-axis tool positioner assembly which places cameras, epoxy syringe, and UV heads.
- 3 digital cameras for vision processing and real-time process monitoring
- Multi-channel power meter/current meter for optical and electrical measurement
- Precise temperature control from +15 °C to +75 °C
- Built-in pneumatic anti-vibration table
- UV safety enclosure
- Fixtures with detachable mechanism for handling the coupling methods including:
  - Edge coupling with optical fiber / fiber block
  - Vertical coupling with optical fiber / fiber block
  - Free space lens alignment
  - Electric probing
- Analog input ports for active alignment with external signal
- Compact system size
- Various alignment methods that can be tuned with many parameters
- Precise gap control and angle alignment of FAB based on displacement sensor
- Vision processing functions and vision-based interactive stage control
- Automatic epoxy dispensing & UV curing for device assembly
- Compatible with various external instruments, including SMUs , laser drivers, and power meters
- Versatile/flexible software with convenient graphic user interface
- TCP/IP server integrated in control software for remote operation

IFA-600-AUCME3: Optical Device Alignment/Bonding/Test System (Rev.09)

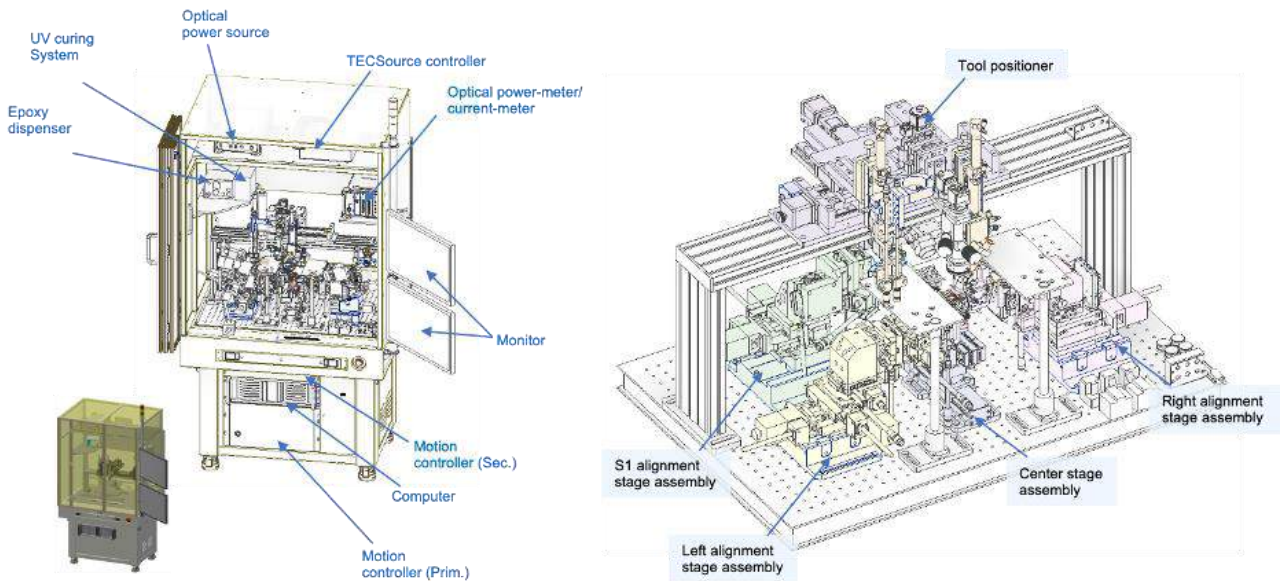

Fig. 1.1 IFA-600-AUCME3: System configuration

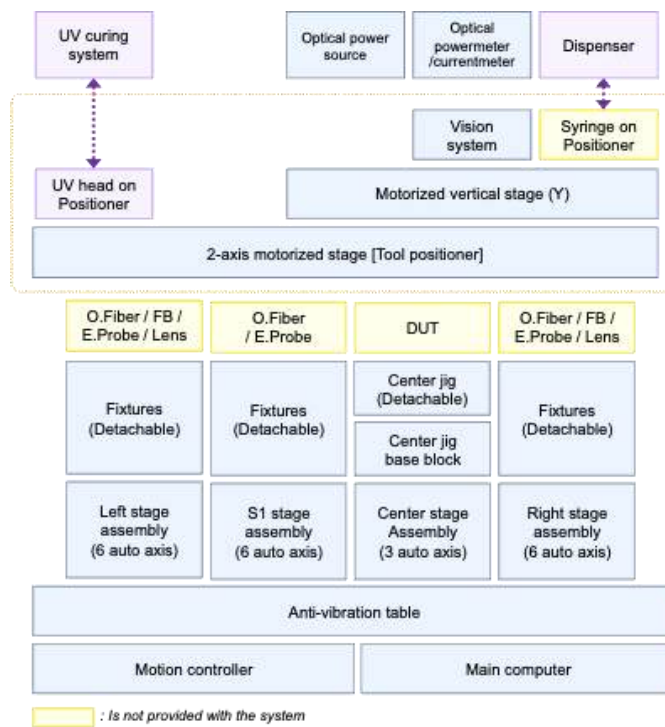

Fig. 1.2: Functional block diagram

## 1.1. Use cases

### 1.1.1. Device Assembly/Test using the active alignment w/ the optical signal

a. Edge coupling

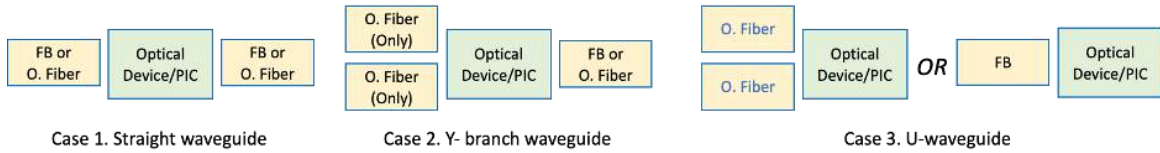

Fig. 1.3 Use case: Edge coupling w/ optical signal

b. Vertical coupling

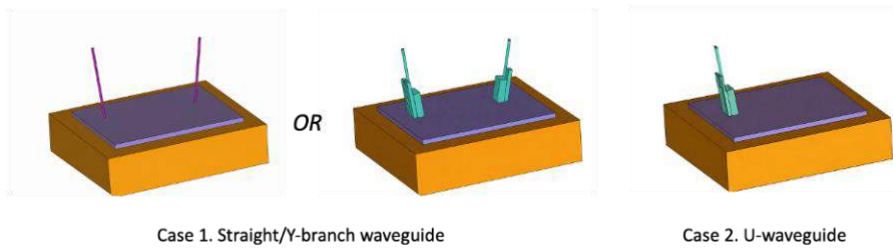

Fig. 1.4 Use case: Vertical coupling w/ optical signal

c. Free space lens coupling

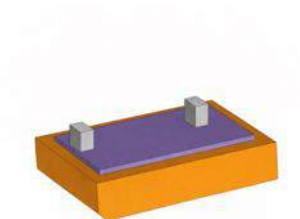

Fig. 1.5 Use case: Free space lens coupling w/ optical signal

### 1.1.2. Device Assembly/Test using the active alignment w/ the optical & electrical signal

a. Edge coupling

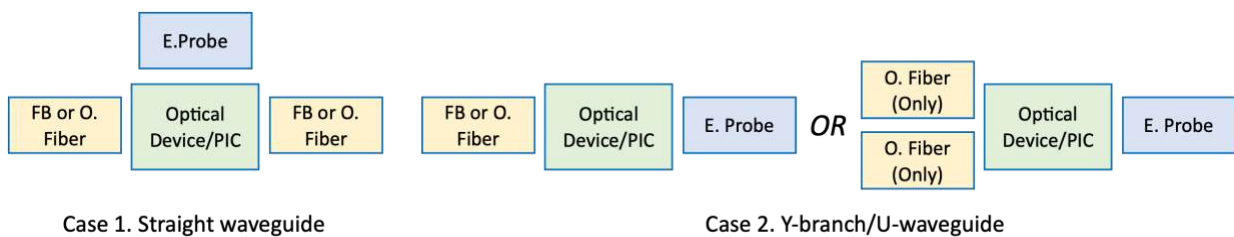

Fig. 1.6 Use case: Edge coupling w/ optical & electrical signal

b. Vertical coupling

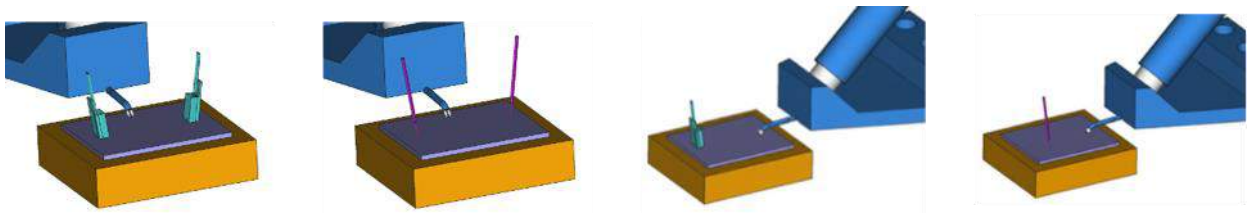

Fig. 1.7 Use case: Vertical coupling w/ optical & electrical signal

c. Free space lens coupling

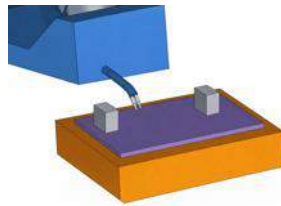

Fig. 1.8 Use case: Free space lens coupling w/ optical & electrical signal

## 2. Specifications

### 2.1. General specifications

- System dimension and weight
  - Dimension (W x D x H) with monitors folded: 1100 x 850 x 2120 (unit: mm)
  - Weight: 400 kg approx.
- Power consumption: 1100 VA max

#### 2.1.1. Requirement for system operation

- Space requirement
  - 2020 mm x 1350 mm x 2300 mm (W x D x H, 2.1)

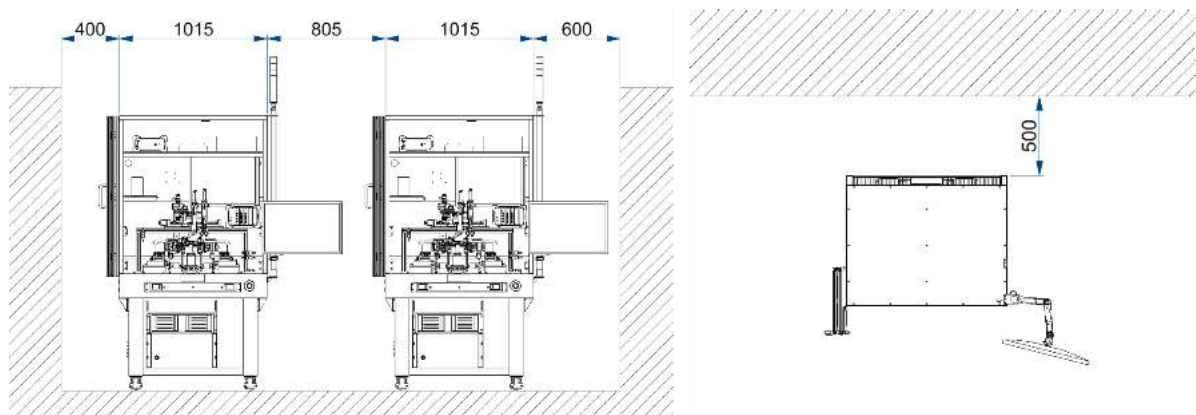

Fig. 2.1: Space requirements

- Requirements for the operation (Required space and utilities)
  - Electric power & connection
    - Voltage requirement: 100 ~ 240 VAC, single phase
    - Power cord: IEC C13 female type plug
  - CDA connection
    - Input pneumatic pressure: 0.5 ~ 1.0 MPa (equiv. to 70 ~ 145 psi)
    - Flow rate: 35 liter/min
    - $6\phi$  air tube

#### 2.1.2. System performance

- Optical alignment stability
  - Test condition
    - Mode field diameter: 10  $\mu\text{m}$
    - Wavelength: 1,550 nm
  - Case #1. Lensed fiber to lensed fiber alignment
    - Peak-to-peak variation of the optical power after alignment to the best position
      - $\leq 0.1$  dB max.
  - Case #2. Lensed fiber – straight waveguide – lensed fiber alignment
    - Peak-to-peak variation of the optical power after alignment to the best position
      - $\leq 0.1$  dB max. @ 25°C
      - $\leq 0.2$  dB max. @ 70°C
- Optical alignment repeatability
  - Peak-to-peak variation of the XY positions for 12 times of XY alignment command
    - $\pm 0.3$   $\mu\text{m}$  max. / interface

- Peak-to-peak variation of the Z position for 12 times of gap control command
  - $\pm 0.5 \mu\text{m}$  max.
- Peak-to-peak variation of the ThZ (Roll) position for 12 times of ThZ alignment command
  - $\pm 0.01^\circ$  max.
- Temperature control for DUT
  - With Arroyo TEC source controller 5305
  - Temperature control range:  $15 \sim 75^\circ\text{C}$
  - Temperature stability:  $< \pm 0.1^\circ\text{C}$
  - Environment temperature:  $25 \pm 3^\circ\text{C}$

## 2.2. Computer system

### 2.2.1. Main parts

- CPU: Intel core i7 or similar
- RAM: 16 Gbytes
- PCI Graphic card: Nvidia chipset
- HDD: 2 Tbytes
- SDD: 500 Gbytes
- Case: Rack mountable 3U
- Operating system: Microsoft Windows 11 (English version)

### 2.2.2. Peripherals

- Multiple LAN ports
- Multiple USB ports
- Multiple serial ports
- PCI GPIB card

### 2.2.3. Displays

- 2 HD-grade displays for GUI and cameras for vision processing

*[Note]: Details can be changed for better engineering*

## 2.3. Alignment stage assemblies

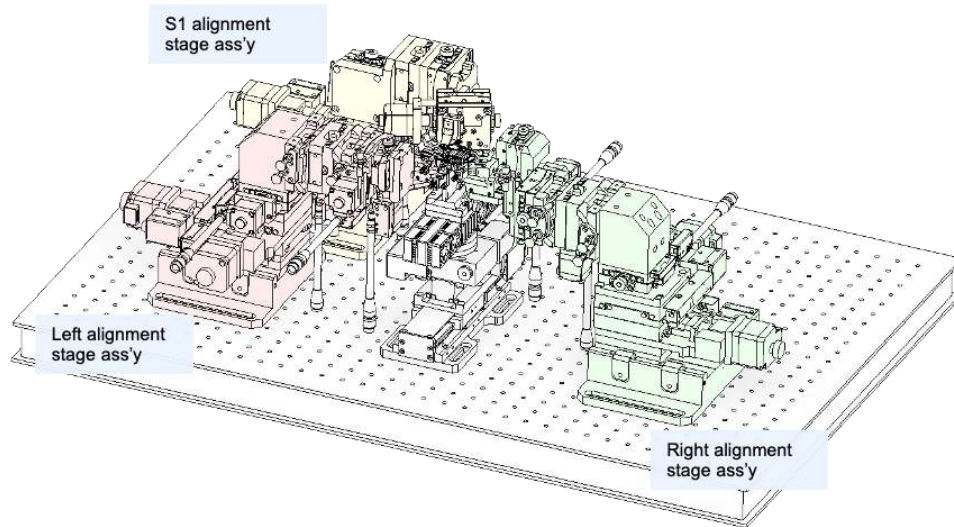

Fig. 2.2 Alignment stage assemblies

- Supplied unit:
  - Left stage assembly: 1 ea
  - Right stage assembly: 1 ea
  - S1 stage assembly: 1 ea
- 6-axis motorized stages
  - 3 linear motorized stages (X, Y, and Z) & 3 rotational motorized stages (ThX, ThY, and ThZ)
  - All automatic precision motorized stages (Manufacturer: Suruga Seiki, Japan)
  - Motors controlled with 1/50 microstep drive
- Fixture-mounting capability for the various types of the alignment
  - Left & Right: optical fiber, fiber block, lens, electric probe
  - S1: optical fiber, electric probe
- A proximity sensor to prevent collision between a stage assembly and a DC probe plate: 1 each on left & right stage assemblies (Total 2 sensors are provided.)
- Angle bracket on Left & Right stage assemblies, which can set the angle of the Y stage to 0°, ±5° and ±8° in  $\theta_x$  axis
- Detachable structure

### 2.3.1. Motorized stages on each stage assembly

- Left & Right stage assemblies

Axis name	Total Travel Length/Angle	Stage Resolution (1/50 microstep)
X	30 mm	≤ 0.1 μm
Y	20 mm	≤ 0.1 μm
Z	30 mm	≤ 0.1 μm
ThX (Pitch)	16° (±8°)	≤ 0.001°
ThY (Yaw)	16° (±8°)	≤ 0.001°
ThZ (Roll)	16° (±8°)	≤ 0.001°

*[Note]: X direction: front-back, Y direction: up-down, Z direction: left-right*

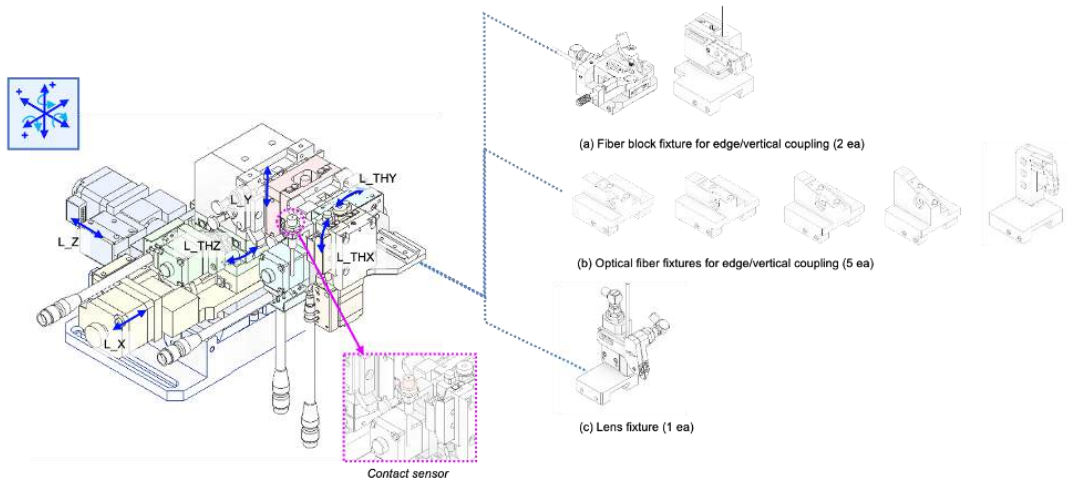

Fig. 2.3 Left alignment stage assembly with fixtures

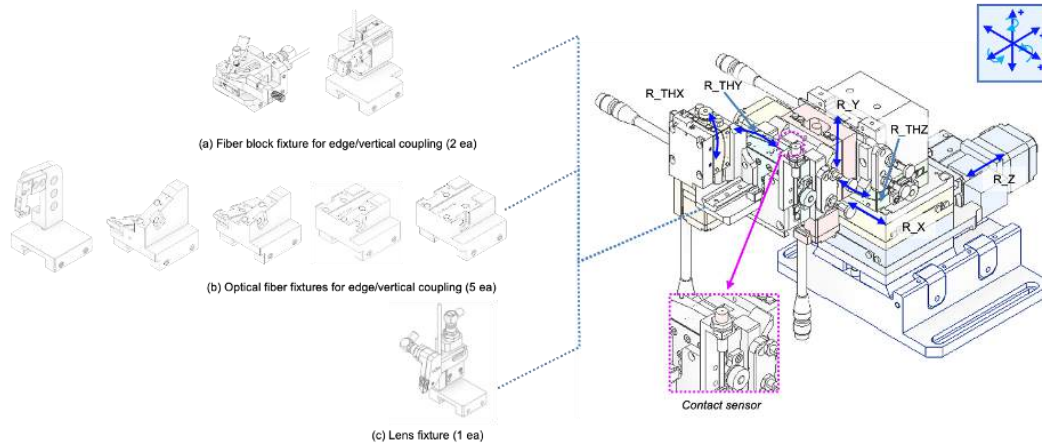

Fig. 2.4 Right alignment stage assembly with fixtures

- S1 stage assembly

Axis name	Total Travel Length/Angle	Stage Resolution (1/50 microstep)
X	30 mm	$\leq 0.1 \mu\text{m}$
Y	20 mm	$\leq 0.1 \mu\text{m}$
Z	30 mm	$\leq 0.1 \mu\text{m}$
ThX (Pitch)	$16^\circ (\pm 8^\circ)$	$\leq 0.001^\circ$
ThY (Yaw)	$12^\circ (\pm 6^\circ)$	$\leq 0.001^\circ$
ThZ (Roll)	$10^\circ (\pm 5^\circ)$	$\leq 0.001^\circ$

[Note: X direction: front-back, Y direction: up-down, Z direction: left-right]

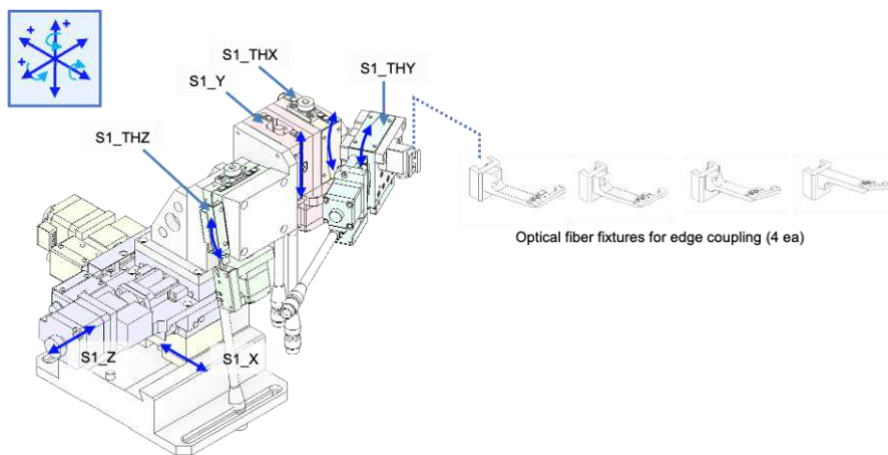

Fig. 2.5 S1 stage assembly with fixtures

### 2.3.2. Angle bracket

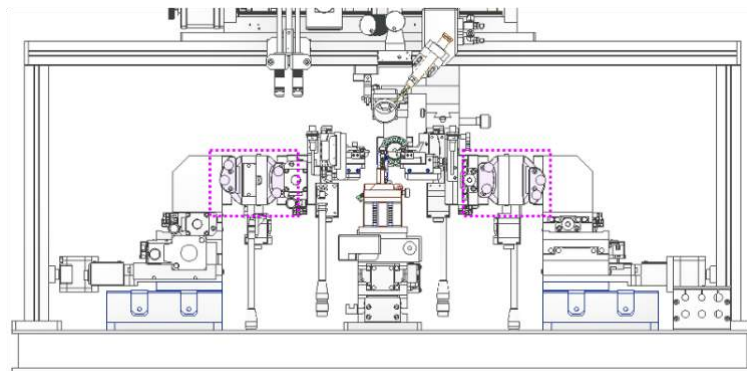

Fig. 2.6 Angle brackets on both stage assemblies

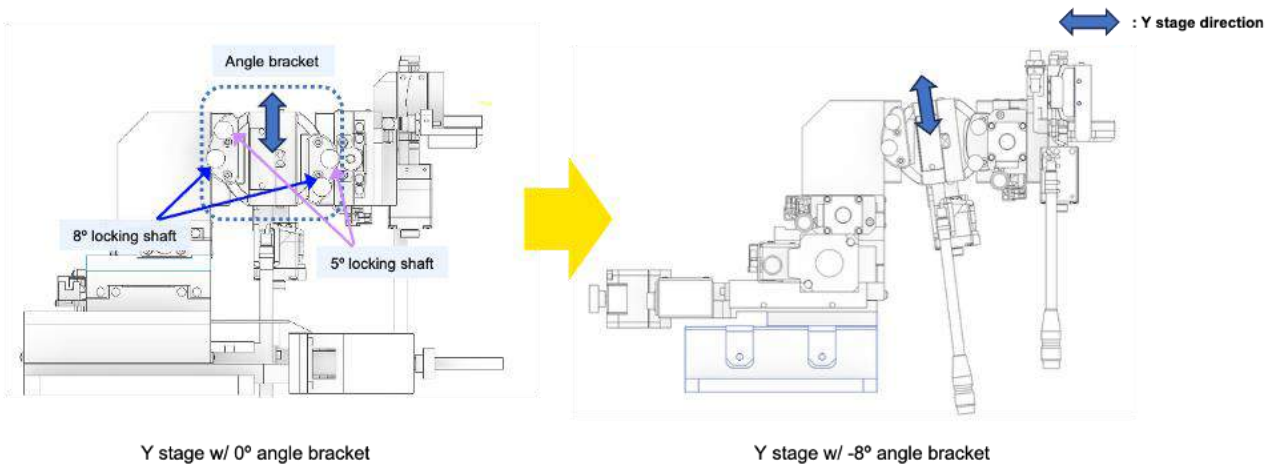

Fig. 2.7 Angle bracket set to 0° and -8°

### 2.3.3. Fiber holder base for the edge coupling

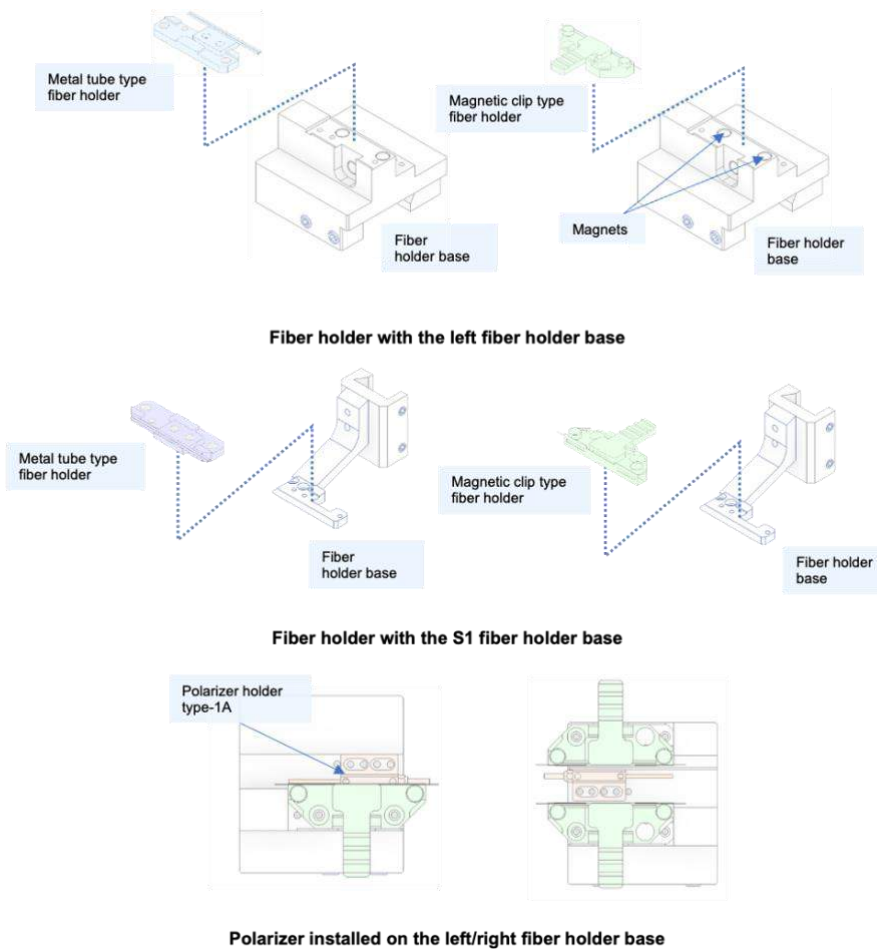

Fig. 2.8 Various items installed on the fiber holder bases

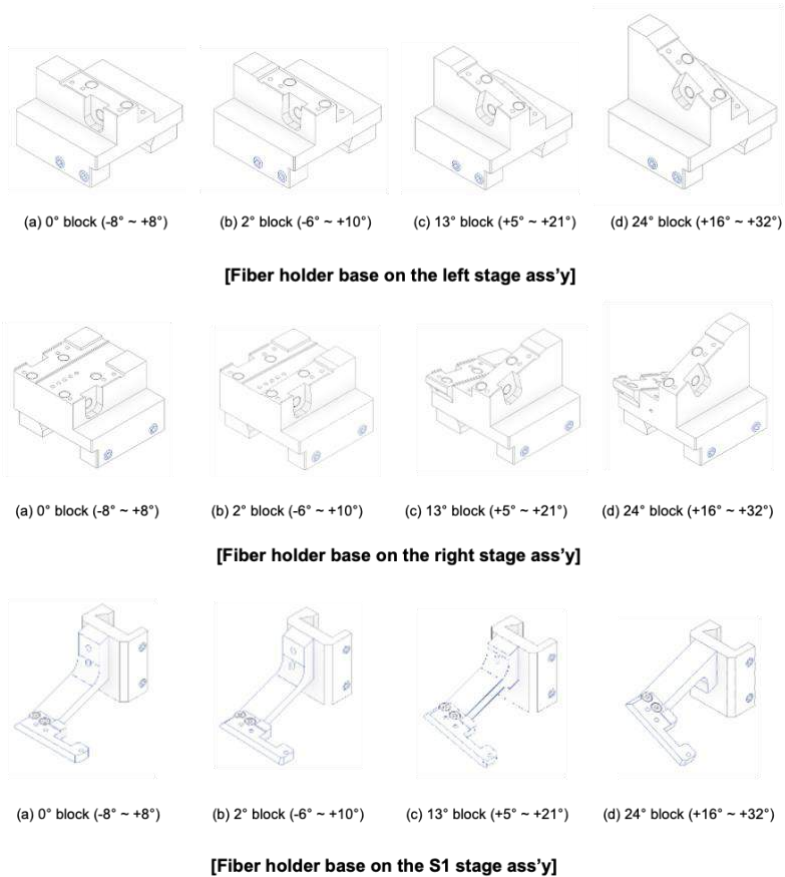

Fig. 2.9 Fiber holder bases for edge coupling

- Three types of the fiber holder bases mounted on each stage assemblies are provided as shown above. (i.e. total 12 holder bases are included.)
  - Left (in ThX direction): 0°, 2°, 13°, 24°
  - Right (in ThX direction): 0°, +/-2°, +/-13°, +/-24° (\*The negative angled slots are for the reference power measurement of the optical fiber mounted on the left and S1 stage assemblies.)
  - S1 (in ThX direction): 0°, 2°, 13°, 24°
- Rotation range (in ThX direction): -8° ~ +8° (\*limited by the travel range of ThX stage)
- Holding type: Mechanical holding with magnets or screws
- The polarizer can be installed on the fiber holder base.
- Installed on the dovetail optical rail

### 2.3.4. Fiber holder base for the vertical coupling

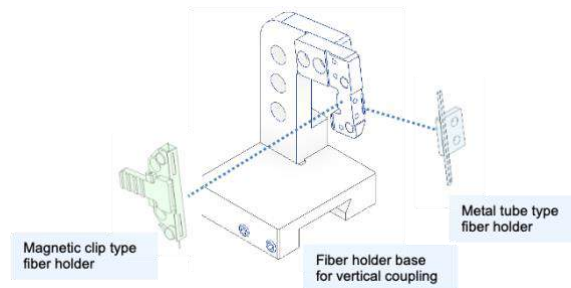

Fig. 2.10 Holder base with the fiber holders (for vertical coupling)

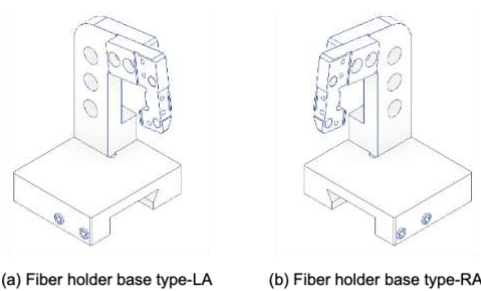

Fig. 2.11 Fiber holder base for vertical coupling

- Supplied unit: 2 ea (Left: 1 ea, Right: 1 ea)
- Holding type: Mechanical holding with magnets or screws
- An optical fiber loaded on the base will be tilted by 82° relative to the ground in ThX direction.
- Rotation range (in ThX direction): -8° ~ +8° (\*limited by the travel range of thX stage)
- Location of the rotation center
  - Metal tube type fiber holder: The fiber tip extends 2 mm from the holder
  - Magnetic clip type fiber holder: The fiber tip extends 3 mm from the holder
- The fiber tip is capable of reaching the center of the fixture in the Z-direction (w/ Center jig type-B, when it is positioned at the rotation center.).

*[Note]: With an object (optical fiber, fiber block, lens, or electric probe) placed on one side of the device, the optical fiber on the other side is limited to the center point of the chip. Consultation with FIBERPRO is required for extended access.*

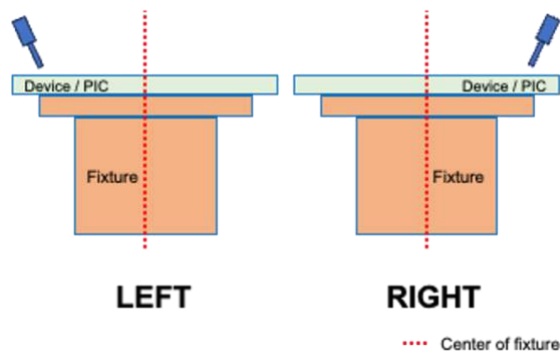

Fig. 2.12 Travel range of the fiber tip on the device from the center of the fixture

- Installed on the dovetail optical rail

### 2.3.5. Optical fiber holders

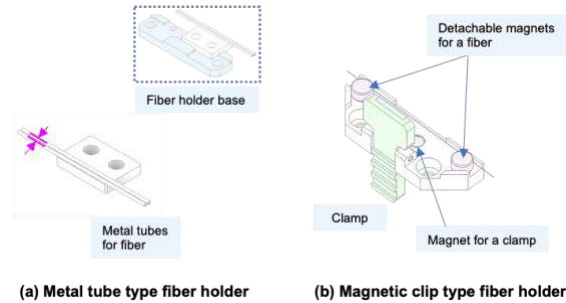

Fig. 2.13 Optical fiber holders

- Two types of the fiber holder are provided.
  - Metal tube type fiber holder & adapter
    - Supplied unit:
      - Adapter: 3 ea
      - Metal tube type fiber: 6 ea (Left-to-Right: 3 ea, Right-to-Left: 3 ea)
    - Holding type: Holding by the glue
    - 2 metal tubes to attach fiber (Metal tube pitch: 750  $\mu\text{m}$ )
    - For the test at high temperature ( $> 50\text{ }^\circ\text{C}$ )
    - Mounted on the adapter to be installed on the fiber holder base
  - Magnetic clip type fiber holder
    - Supplied unit: 3 ea
    - Holding type: Mechanical clamping with magnets
    - Thickness of the side edge of the magnetic fiber holder: 100  $\mu\text{m}$  (Minimum pitch of the optical fibers on both S1 and left stage: 500  $\mu\text{m}$ )
  - Both types for the fiber holders are installed on the fiber holder base.

### 2.3.6. Fiber block fixture for edge coupling

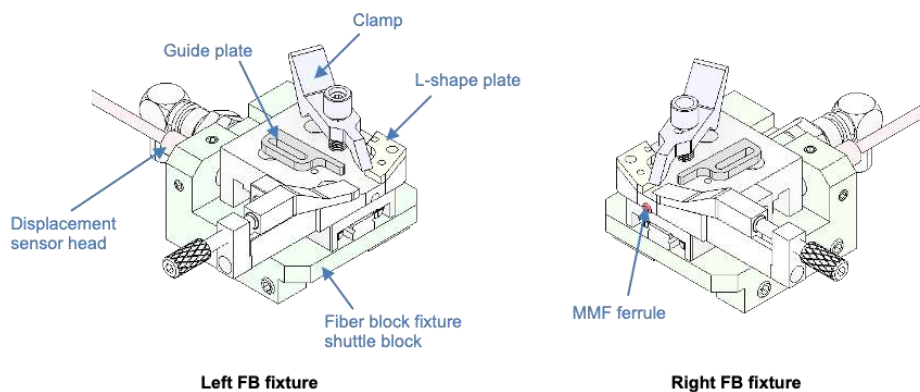

Fig. 2.14 Fiber block fixtures for edge coupling

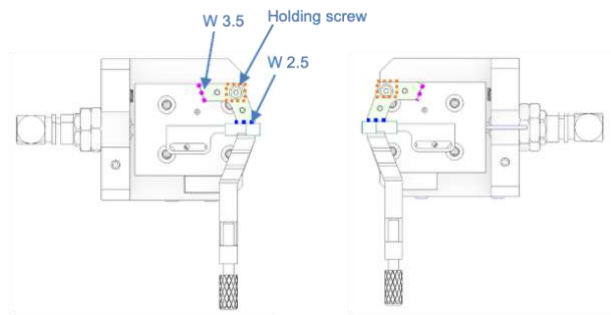

Fig. 2.15 L-shape plate

- Supplied unit: 2 ea (Left: 1 ea, Right: 1 ea)
  - Holding type: Mechanical holding using screw
  - Applicable fiber block dimension (WxH):
    - 2.5 mm x 2.5 mm
    - 3.5 mm x 2.5 mm
  - *[Note]: A minimum chip thickness of 700 μm is required to guarantee gap control and angle alignment performance.*
  - *[Note]: For other sizes or polished angle of fiber blocks, please consult with FIBERPRO.*
  - The fixture design is optimized for handling device with 0° facet angle. (Fixture angle: 0° relative to the z-axis)
  - L-shape plate makes the center of the specific fiber block (2.5 mm and 3.5 mm width) matched with the center of rotation of the stage assembly. (Screw size: M2)
  - Guide plate for the easy mount of the fiber block
  - Vertical clamp for holding the fiber block
  - The MMF ferrule installed on the right fiber block fixture for the input alignment
  - Pneumatic fixture position locking function
  - Displacement sensor mounting hole
  - Capable of holding an optical fiber *[Note: a hollow metal tube required]*
  - Detachable fixture
  - Installed on the dovetail optical rail
- [Note]: Detail design can be changed for better engineering*

### 2.3.7. Fiber block fixture for vertical coupling

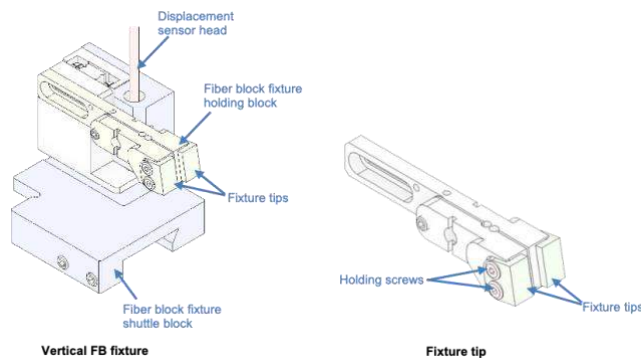

Fig. 2.16 Fiber block fixtures for vertical coupling

- Supplied unit: 2 ea (Left: 1 ea, Right: 1 ea)
- Holding type: Mechanical holding using screw (Screw size: M3, recommended torque: 0.5 kgf/cm)
- Applicable fiber block dimension (WxH):

- 2.5 mm x 2.5 mm
- 3.5 mm x 2.5 mm

*\*For other sizes or polished angle of the FABs, please consult with FIBERPRO.*

- Fixture angle: 82° (relative to the horizontal plane in Thx direction)
- Location of the rotation center: The fiber block extends 2 mm from the fixture tips.
- The center of fiber block is capable of reaching the center of the fixture in the Z-direction (w/ Center jig type-B, when it is positioned at the rotation center.).

*[Note]: With an object (optical fiber, fiber block, lens, or electric probe) placed on one side of the device, the fiber block on the other side is limited to the center point of the chip. Consultation with FIBERPRO is required for extended access.*

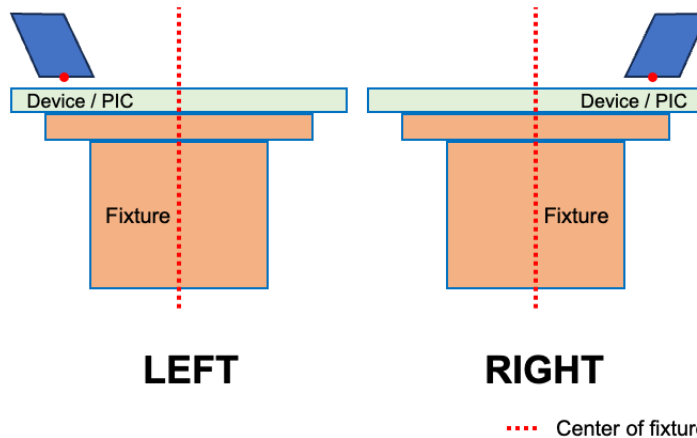

Fig. 2.17 Travel range of the fb on the device from the center of the fixture

- The fixture tip makes the center of the specific fiber block (2.5 mm and 3.5 mm width) matched with the center of rotation of the stage assembly. (Screw size: M2)
- Displacement sensor mounting hole
- Detachable fixture
- Installed on the dovetail optical rail

*[Note]: Detail design can be changed for better engineering*

### 2.3.8. Lens fixture

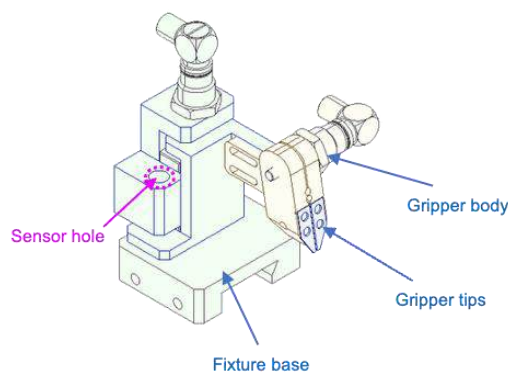

Fig. 2.18 Lens fixture

- Supplied unit: 2 ea (Left: 1 ea, Right: 1 ea)
- Holding method: Mechanical holding using pneumatic action

- Applicable lens dimension (W x L x H, mm):
    - 1 mm x 1 mm x 1.5 mm
    - 1 mm x 0.5 mm x 1 mm
  - *\*For other sizes or polished angle of the lens, please consult with FIBERPRO.*
  - Location of the rotation center: gripper tip end
  - The center of the lens is capable of reaching the center of the fixture in the Z-direction (w/ Center jig type-B, when it is positioned at the rotation center.).
- [Note]: With an object (optical fiber, fiber block, lens, or electric probe) placed on one side of the device, the lens on the other side is limited to the center point of the chip. Consultation with FIBERPRO is required for extended access.*

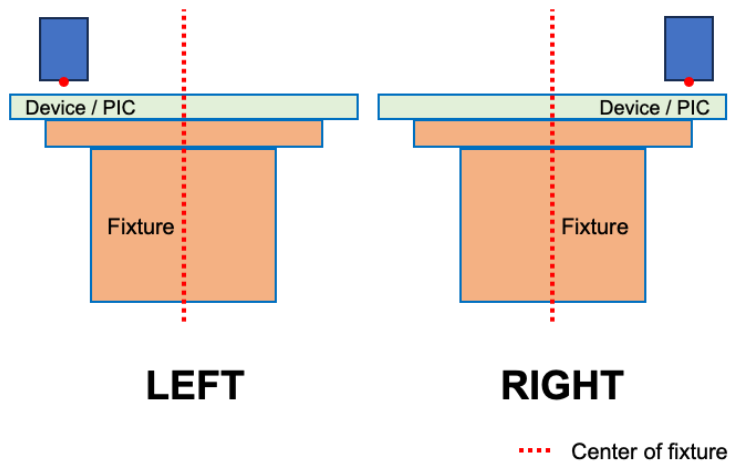

Fig. 2.19 Travel range of the lens on the device from the center of the fixture

- Pneumatic fixture position locking function
- Displacement sensor mounting hole
- Detachable fixture
- Installed on the dovetail optical rail

### 2.3.9. Electric probe holders

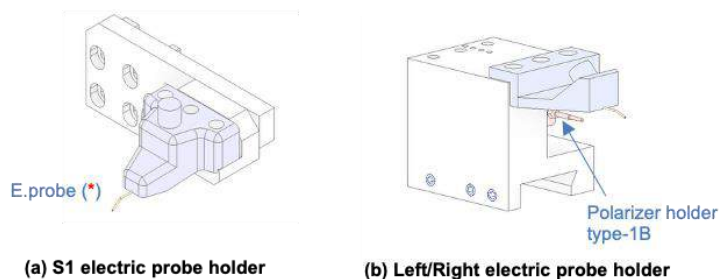

Fig. 2.20 Electric probe holders

- Supplied unit:
  - Electric probe holder on the S1 assembly: 1 ea
  - Electric probe holder on the Left/Right assembly: 1 ea
- The tip of a RF probe is placed at the point stuck out from the rotation center by 8 mm.
- 40A-GSG-100-P (GSG) or equal dimensions (link: <https://ggb.com/home/model-40a/>)

- The electric probe tip mounted on left/right electric probe holder is capable of reaching the center of the fixture in the Z-direction (w/ Center jig type-B).  
*[Note]: With an object (optical fiber, fiber block, lens, or electric probe) placed on one side of the device, the lens on the other side is limited to the center point of the chip. Consultation with FIBERPRO is required for extended access.*

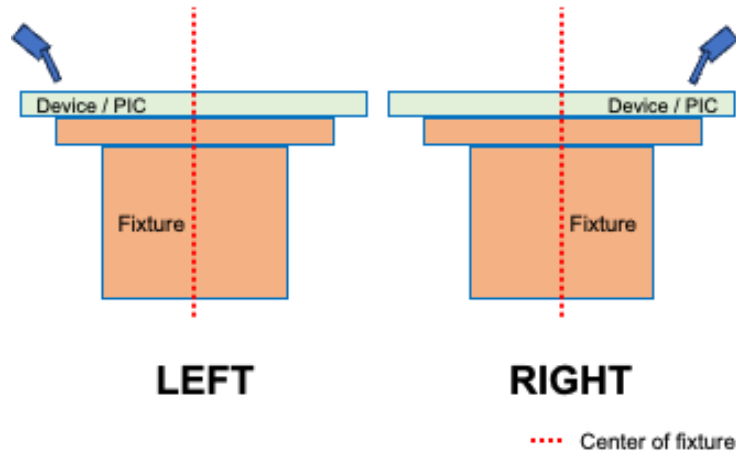

Fig. 2.21 Travel range of the electric probe on the device from the center of the fixture

- Detachable type
  - Installed on the dovetail optical rail
- [Note: An electric probe is not a part of the system.]*

### 2.3.10. Multimode fiber with polarizer

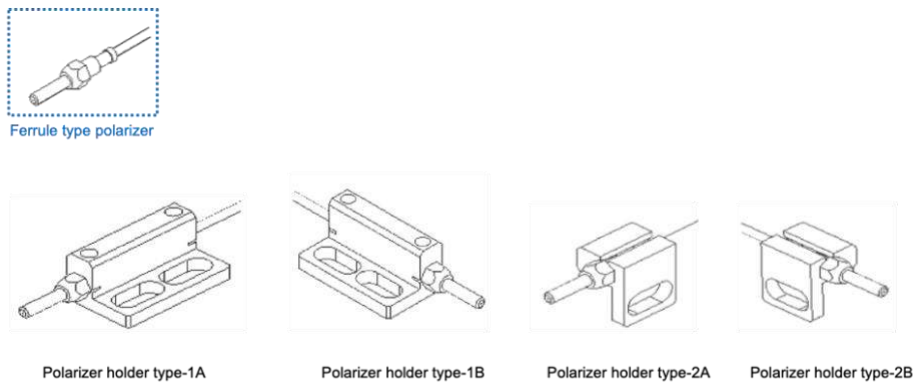

Fig. 2.22 Polarizer & polarizer holder

- Supplied unit:
  - Type-1A (Long type loaded on the left/right fiber holder): 1 ea
  - Type-1B (Long type loaded on the left/right E probe holder): 1 ea
  - Type-2A (Short type loaded on the center jig): 1 ea
  - Type-2B (Short type loaded on the center jig): 1 ea
- Multimode fiber ferrules (LC/PC) with polarizer
- Installed on either a fiber holding block, a right RF probe holding block, or a center jig

## 2.4. Center stage assembly and center jigs

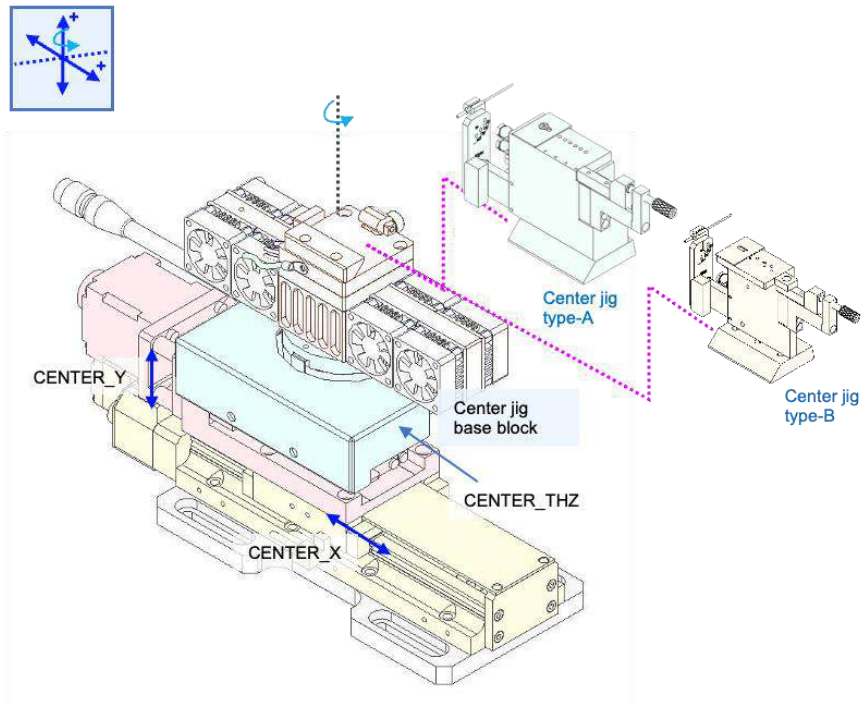

Fig. 2.23 Center stage assembly and center jigs

### 2.4.1. Center stage assembly

- Supplied quantity: 1 unit
- 2 linear motorized stages (X, Y) & 1 rotational motorized stage (ThY)

Axis name	Total Travel Length/Angle	Stage Resolution (1/50 microstep)
X	100 mm	$\leq 0.1 \mu\text{m}$
Y	4 mm	$\leq 0.1 \mu\text{m}$
ThY	$\pm 20^\circ$	$\leq 0.001^\circ$

*[Note: X direction: front-back, Y direction: up-down, Z direction: left-right]*

- Capable of mounting the center jig base block

### 2.4.2. Center jig

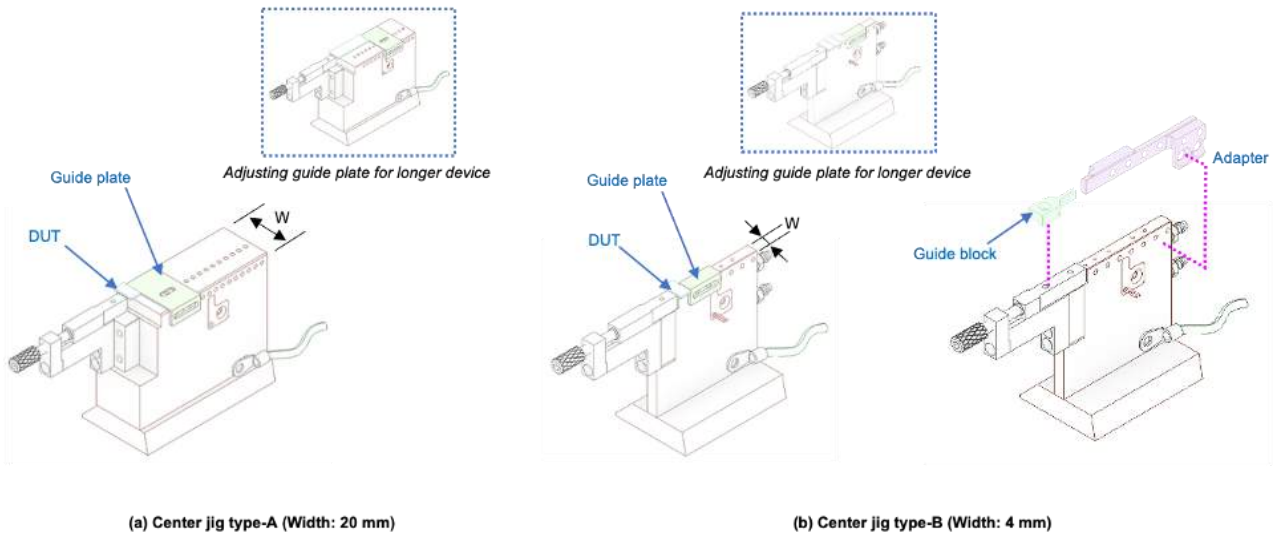

Fig. 2.24 Center jigs

- Supplied unit:
  - Type-A (Center jig for single side coupling): 1 ea
  - Type-B (Center jig for dual side coupling): 1 ea
- Center jig-type-A
  - Holding type: Mechanical fix using screw / vacuum fix for initial mounting
  - Mounted on the center jig base block
  - Width: 20 mm
- Center jig-type-B
  - Holding type: mechanical holding with screw & vacuum
  - Mounted on the center jig base block
  - Width 4 mm
  - Various width of the adapters with the guide block
    - a: 2 mm ~ 5 mm (W: 1.5 mm)
    - b: 9 mm ~ 12 mm chip can be installed. (W: 8 mm)
    - c: 13 mm ~ 16 mm chip can be installed. (W: 12 mm)
    - d: 17 mm ~ 20 mm chip can be installed. (W: 16 mm)
- *\*The type-b, c, d adapters have the hole for the alternative position of the thermistor.*
- Thermistor installed on the center jig

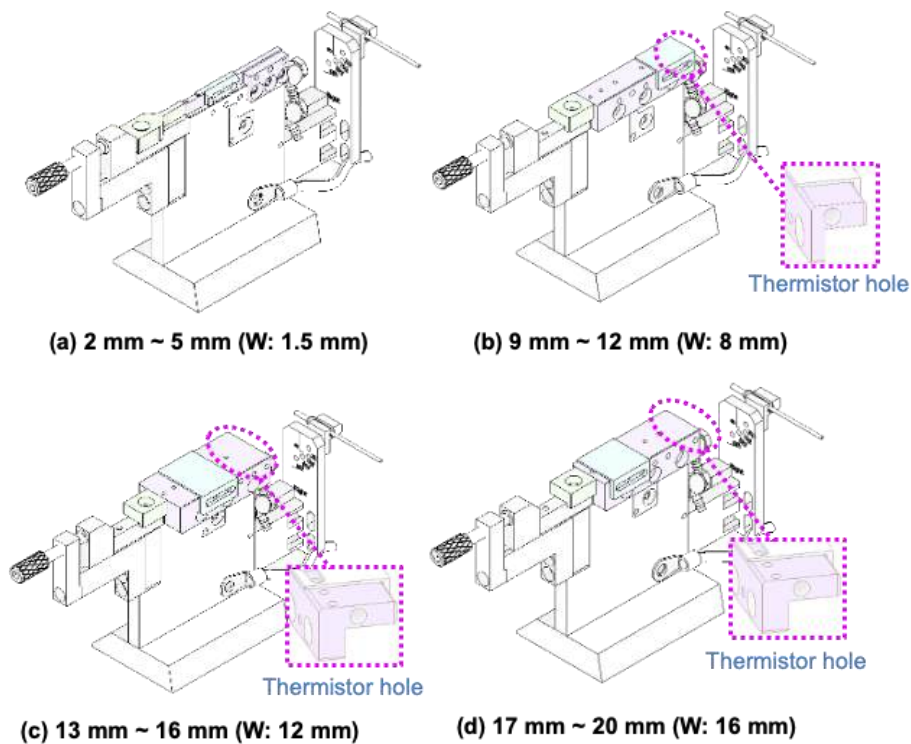

Fig. 2.25 Center jig-type “B” with the various adapters

- Polarizer loading block
  - Supplied unit: 2 ea (Left: 1 ea, Right: 1 ea)
  - A polarizer (with holder type-2A & 2 B) can be installed on the side edge of both center jigs with screw.
  - Various holes with the guideline (0°, 2°, 13°, 24°, 82°) to show the polarizer-end and the device on the rear camera view.
  - Adjustable position in vertical direction. (\*The polarizer position should be moved up if the center jig is used with the adapter to see the polarizer-end and the device on the rear camera view.)
  - Dual-sided design
    - “Left” panel (input beam direction: left-to-right)
    - “Right” panel (input beam direction: right-to-left)

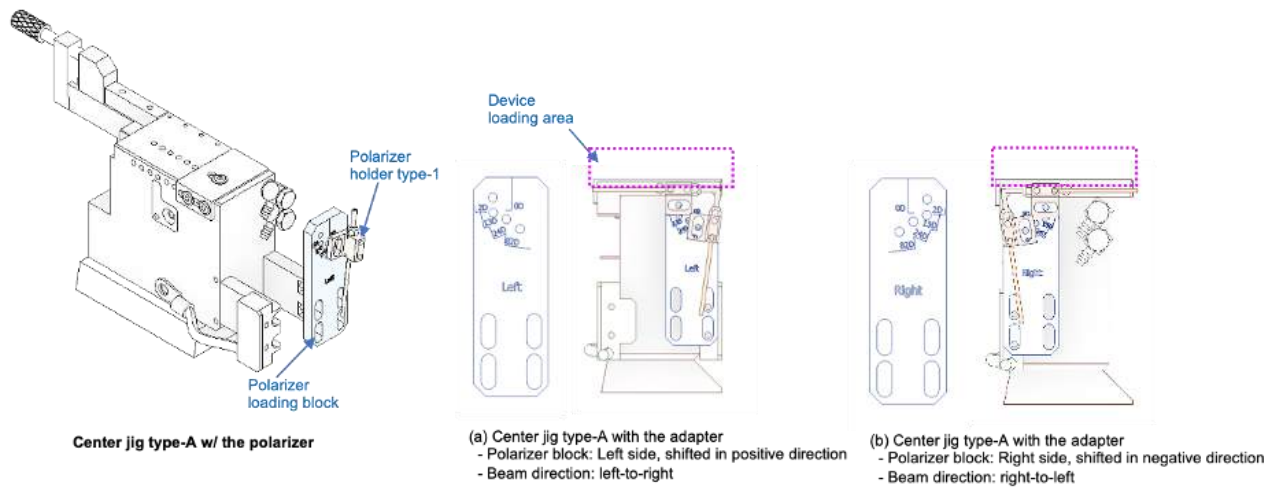

Fig. 2.26 Center jig type-A with the polarizer loading block

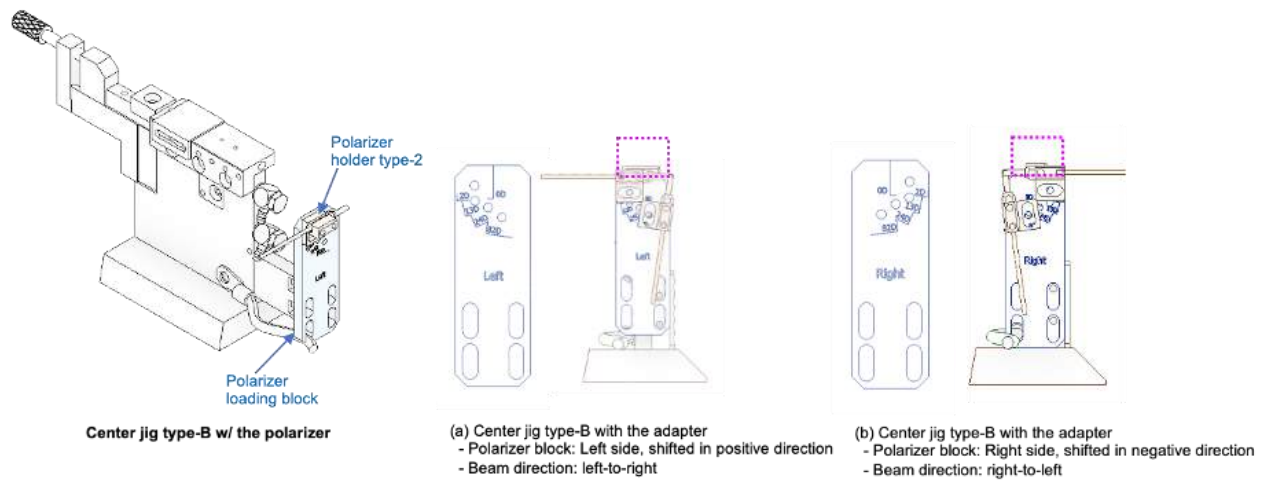

Fig. 2.27 Center jig type-B with the polarizer loading block

### 2.4.3. Center jig base block

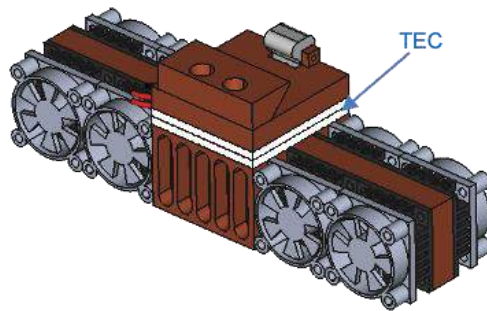

Fig. 2.28 Center jig base block

- Supplied quantity: 1 unit
- Mounted on the center stage assembly
- Temperature control
  - Heating/cooling type: thermoelectric cooler
  - Operation with a thermistor on the center jig
  - Performance (w/ Arroyo TEC controller 5305)
    - Temperature control range: 15 ~ 75 °C
    - Temperature stability: <math>\pm 0.1\text{ }^\circ\text{C}</math>
    - Environment temperature: 25±3 °C

*[Note]: Temperature control performance can be changed if the user uses other TEC controller.*
- Cooling fan(s) installed on heat sink. Automatic on/off control by system.

### 2.5. Tool positioner

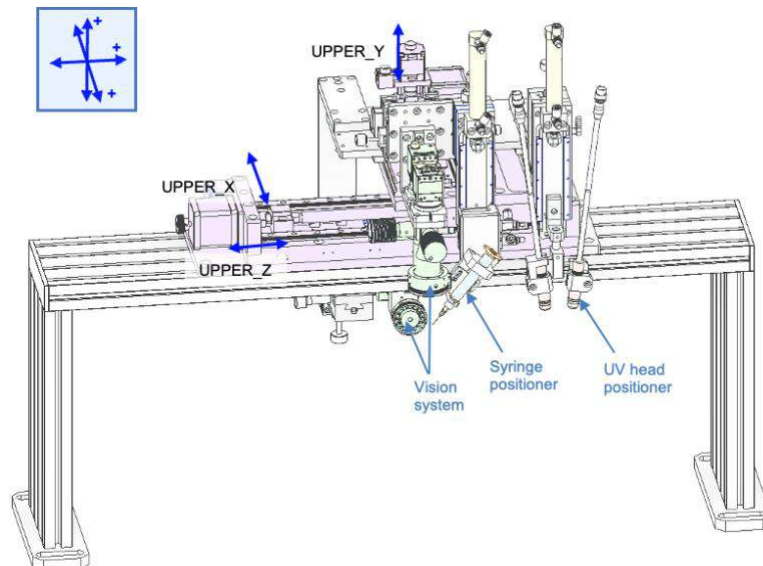

Fig. 2.29 Tool positioner

- Supplied quantity: 1 ea
- 3 linear motorized stages (X,Y, and Z)

- All automatic precision motorized stages (Manufacturer: Suruga Seiki, Japan)
- Motors controlled with 1/50 microstep drive

Axis name	Total travel length/angle	Stage Resolution (1/50 microstep)
X	75 mm	0.2 $\mu\text{m}$
Y	15 mm	0.04 $\mu\text{m}$
Z	200 mm	0.2 $\mu\text{m}$

- Positioning the tools such as vision system, epoxy syringe and UV heads
- Rear fan for better temperature control is installed on the tool positioner

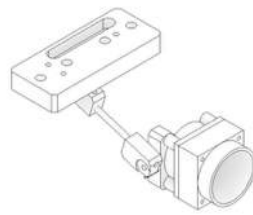

Fig. 2.30 Rear fan

## 2.6. Vision system

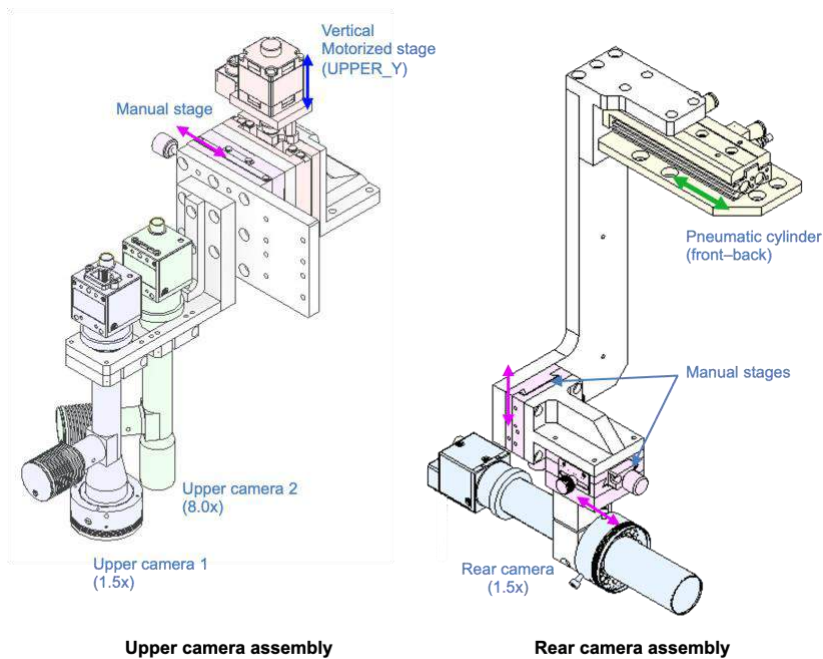

Fig. 2.31 Vision system

- Upper camera assembly
  - Supplied quantity: 1 ea
  - Upper camera 1
    - 1/3 inch CCD/CMOS camera, 1440x1080 pixels
    - 1.5x microscope with working distance of 110 mm

- Field of View (FOV): 3312  $\mu\text{m}$  x 2484  $\mu\text{m}$
- Ring type LED lamp
- Coaxial type lamp
- Upper camera 2
  - 1/3 inch CCD/CMOS camera, 1440x1080 pixel
  - 8.0x microscope with working distance of 110 mm
  - Coaxial type lamp
- 1-axis manual stage
 

*[Note]: Upper camera assembly is mounted on a Y-axis motorized stage integrated with the tool positioner for focus control.*
- Rear camera assembly
  - Supplied quantity: 1 ea
  - Rear camera
    - 1/3 inch CCD/CMOS camera, 1440x1080 pixels
    - 1.5x microscope with working distance of 156 mm
    - Field of View (FOV): 3312  $\mu\text{m}$  x 2484  $\mu\text{m}$
  - View angle: 0° with relative to the horizontal line
  - Pneumatic cylinder for position shift
  - Ring type LED lamp
  - 2-axis manual stages

## 2.7. UV curing system and UV head positioner

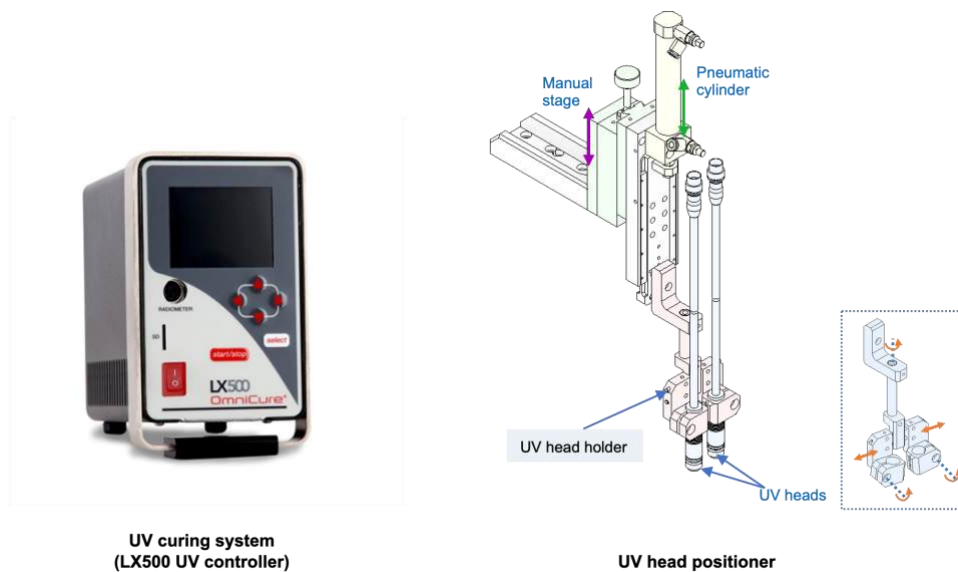

Fig. 2.32 UV curing system and UV head positioner

- UV curing system
  - Supplied quantity: 1 unit
  - LX500 UV LED Spot Curing System Controller (<https://www.excelitas.com/product/omnicure-lx500-uv-led-spot-curing-system-controller>)
  - Intensity Level: 5-100% (with 1% increments)
  - External Control Description: Via optional foot pedal, PLC, or PC through USB communication.
  - 3 mm UV LED heads (365 nm): 2 ea
  - Automatic start/stop control by system software

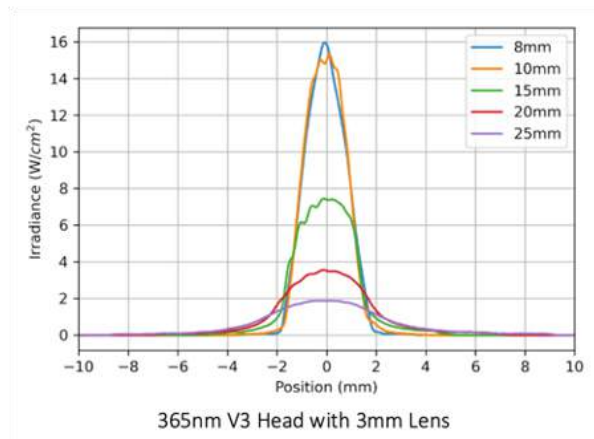

Fig. 2.33 UV beam profile (w/ 3 mm lens)

- UV head positioner
  - Supplied quantity: 1 unit
  - 1 detachable UV head holder
  - Automatic positioning of the holder in up/down direction
  - 1 axis manual stage for vertical position adjustment
  - Installed on the tool positioner

## 2.8. Epoxy dispenser and syringe positioner

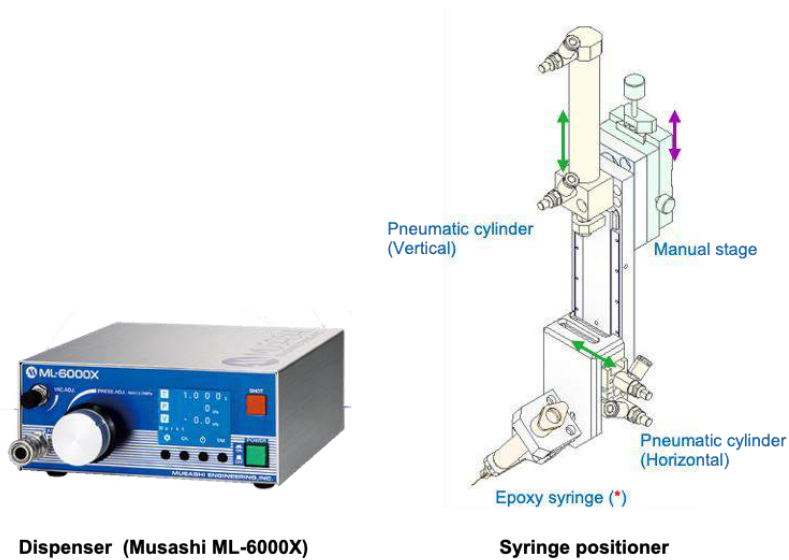

Fig. 2.34 Epoxy dispenser and syringe positioner  
 (\*: Is not provided with the system)

- Epoxy dispenser
  - Supplied quantity: 1 unit
  - Musashi ML-6000X-CTR-N-GP (<http://www.musashi-engineering.co.jp/>)
  - Dispensing Pressure Adjustment Range: 5.0 to 700.0 kPa (Maximum Supply Air Pressure: 800 kPa (Dispensing Pressure +100 kPa or More))

- Vacuum Pressure Setting Range: 0 to -20.0 kPa
- Discharge time setting: 0.001 to 99.999 sec, 0.01 to 999.99 sec, 0.1 to 9, 999.9 seconds (Enable to switch digits by Icon Keys)
- Interface: RS-232 Serial Communication
- Control by system software available
- Syringe positioner
  - Supplied quantity: 1 unit
  - Applicable syringe: PSY-SEU-OR (3 ml) or similar dimensions ([https://www.musashi-engineering.co.jp.k.cn.hp.transer.com/products/syringe/syringe/PSY-FU-OR](https://www.musashi-engineering.co.jp/k.cn.hp.transer.com/products/syringe/syringe/PSY-FU-OR))
  - Automatic positioning of syringe needle in 2 directions (Y, Z) based on pneumatic cylinder
  - 1 axis manual stage for vertical position adjustment
  - Installed on the Y motorized stage of the tool positioner (Fine vertical position control can be done with the Y stage)

## 2.9. PM2100: Optical power meter/current meter

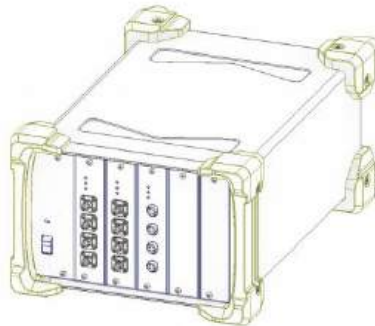

Fig. 2.35 PM2100: Multichannel Optical Power Meter

- Supplied quantity: 1 unit
- Optical power-meter module
  - Number of channels: 4
  - Wavelength range: 1250 ~ 1630 nm
  - Dynamic range: +10 dBm ~ -80 dBm
  - Total uncertainty: +/- 5.6 % @ > -60 dBm
- Current meter module
  - Number of channels: 4
  - Dynamic range: +3 ~ -70 dBmA (2 mA ~ 100 pA)
  - Accuracy: 0.2 dB @ > -45 dBmA
- 2 analog output ports

## 2.10. MDU1000: Multi-purpose drive unit



Fig. 2.36 MDU1000: Multi-purpose drive unit

- Supplied quantity: 1 unit
- Optical light source
  - Source type: DFB laser, wavelength: 1550 nm
  - Number of output channels: 4
  - Output power:  $\geq -1$  dBm / channel
  - Number of power monitoring port (coupling: -10dB): 1
  - FC/APC optical connectors
- Current source
  - Channel: 4
  - Current output: 200 mA max.
  - The maximum current output is 200mA/ch when all the channels are driven. The maximum current for single channel driving is 300 mA.  
*[Note]: 300mA driving current is only for short period time(e.g. for 5 minutes). For longer driving time, a commercial laser driver should be used.*
  - Current control resolution: 2 mA typical
  - Current output error: 3% + 2mA
  - Output voltage: 0 ~ 4.5 V max

## 2.11. TEC controller



Fig. 2.37 5305: TEC controller

- Supplied quantity: 1 unit
- Arryo 5305 (<https://www.arroyoinstruments.com/product-category/temperature-controllers/5300-series-tecsource/>)
  - Current range: +/-5 A
  - Compliance voltage: 12 VDC
  - Max power: 60 W

## 2.12. DC probe plate



- Supplied quantity: 2 ea
- Can be mounted on an optical table using tightening screws.

## 2.13. Motion controller

### 2.13.1. SC7000: Primary motion controller

- Supplied quantity: 1 unit
- No. of axes controllable: 16
- 5-phase micro-step motor drivers. (Configured for 1/50 micro-stepping)
- 2 analog input ports are included
  - Voltage range: 0~5 V
  - Input impedance: 10 kOhm

### 2.13.2. SC3000: Secondary motion controller

- Supplied quantity: 1 unit
- No. of axes controllable: 8
- 5-phase micro-step motor drivers. (Configured for 1/50 micro-stepping)

### 3. Control Software

#### 3.1. Features

- Various alignment functions capable of handling different types of device (Straight, Y-branch, U shape waveguide, etc).
  - The functions are
    - Fast 2-dimensional blind search in linear plane (suitable for waveguide alignment)
    - Fast 2-dimensional angular blind search (suitable for collimated beam alignment)
    - Fine 1-dimensional alignment in linear and angular direction.
    - Roll alignment in ThX, ThY and ThZ directions
      - with one channel for the U-waveguide
      - with two channels for the multiple waveguides
  - Capable of user-programmable sequence and macro commands
  - Various system variables and user-defined variables that can be used in the sequence
  - Various graphs that display data generated during the alignment process
  - Various vision processing functions such as template matching, on-chip barcode reading, automatic probe positioning
  - External SMU interface supported (Keysight B2602, Keithley 2400)
  - External power-meter interface supported (Thorlabs PM5020)
  - Supporting remote control of client’s software via TCP/IP communication
  - Automatic start/stop control by system software (Supported systems: Exelitas LX500, Musashi ML-6000X)
- [Note]: For integration of instruments not listed above, please consult with FIBERPRO in advance.*

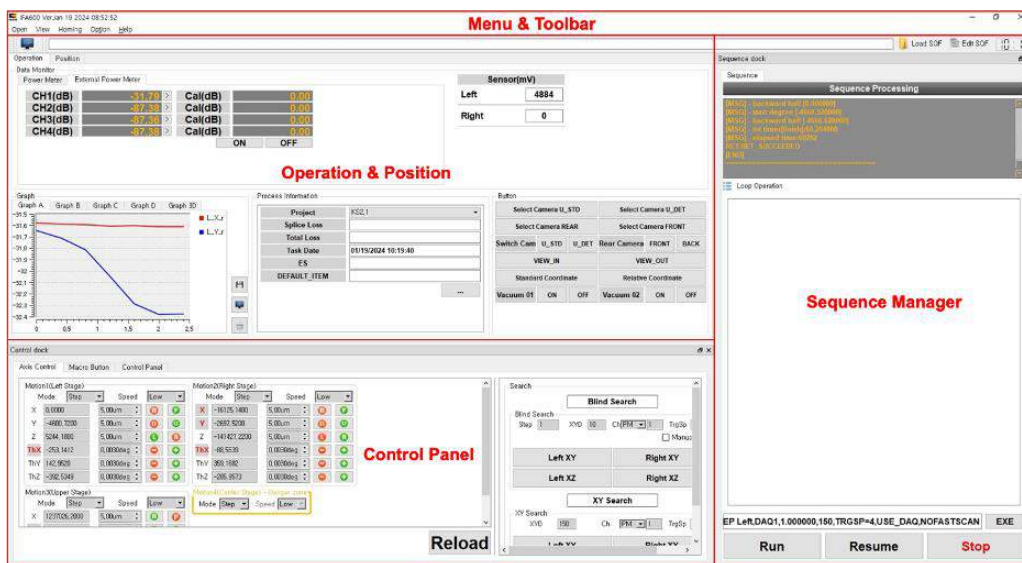

Fig. 3.1 Main window layout

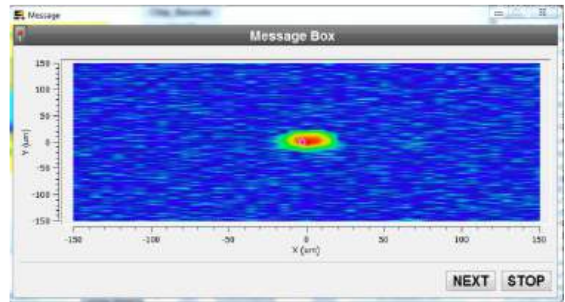

Fig. 3.2 2D scan window



Fig. 3.3 User-definable macro buttons

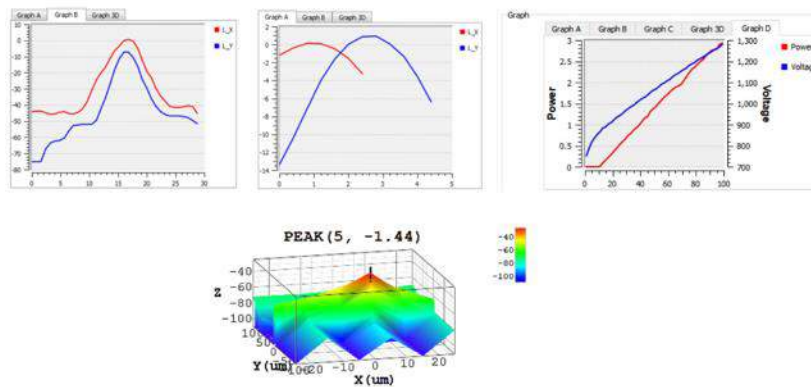

Fig. 3.4 Graph windows



Fig. 3.5 Macro button

### 3.2. Remote control

The IFA-600 software provides a network service based on TCP/IP for remote operation. A simple block diagram is shown

in the figure below.

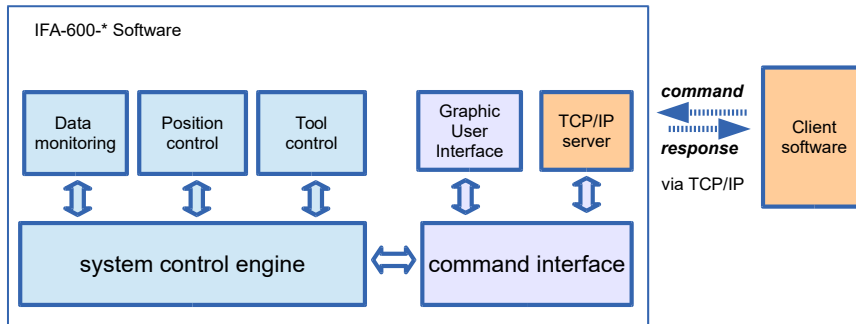

Fig. 3.6 Remote operation of IFA-600 software

The advantages of TCP/IP based servers are

- Easy to program/debug client programs
- Client program can run on a different host even with different operating system. Readily-available terminal programs such as telnet client can be used for the remote operation

The user can control most of functions of IFA-600 including:

- Moving motorized stages
- Reading optical powers/ photo currents
- Alignment
- Control of UV light source, dispenser, etc

[End of Document]